



BVA[®]
HYDRAULICS

INDUSTRIAL HYDRAULIC EQUIPMENT



The BVA Advantage

BVA Industrial Hydraulics was launched in 2005 and is centrally located in Europe in Etten-Leur, The Netherlands. BVA is one of the Shinn Fu Europe brands besides Omega Lift, Omega Mechanix and Prolift. Shinn Fu was founded in Taiwan in 1971 and began doing business in Europe in 1994. Shinn Fu has over 2,000 Employees worldwide with its headquarters in Taipei, Taiwan.

Confidence Built on Quality

ISO 9001

BVA products are manufactured through an International Quality Assurance System, ISO 9001 which involves consistent observation of administration, management, manufacturing, and production control. Under this system, the related operations are monitored on all aspects from purchase order to assembly line and to shipping the order.

BVA Products comply with the following industry standards

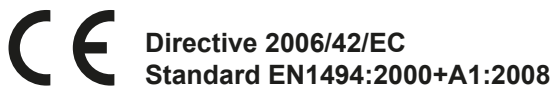

ASME B30.1

The cylinders comply with load testing requirements and / or the safety factor for material yield strength while still functioning properly without oil leakage.

ANSI B40.1

BVA pressure gauges meet the criteria for grade A.

SAE 100

BVA hydraulic hoses comply with the Material Handling Institute's specification of minimum life cycles and minimum burst pressure rating.

BVA Limited Lifetime Warranty

BVA products are warranted to be free of defects in materials and workmanship. Any BVA product that does not conform to specification will be repaired or credited (at BVA's option) at BVA's expense for the life of the product. Contact BVA for disposition of this warranty.

This warranty does not cover ordinary wear and tear, abuse, misuse, alteration or use of improper fluids or maintenance as determined by BVA and its authorized service centers. All electric motors, gas engines, batteries and other parts or materials sold with or part of BVA products but are separately warranted by another manufacturer, are covered by that manufacturer's warranty and not the BVA Lifetime Warranty. BVA shall not be liable for consequential or incidental damage or loss.



Repair Parts
We offer a large range of product replacement parts, please contact your local BVA dealer for more details.



Contact
For technical support, or for questions about your product, contact your local BVA dealer.



BVA Website
To view our most up-to-date catalog or view our new product, visit our website: www.BVAhydraulics.com

Model Number Index

H	6	HLN	18	HC	30	HULN	38	HP	42
HD	10	HLNF	20	HDC	32	HUC	39	HPD	43
HL	14	HG	22	HU	34	HUDC	40	Accessories	44
HF	16	HDG	26	HDU	36	HT	41		

Cylinders



Pages 5-45

P	Single Acting Hand Pumps	48	PA	All Position Air Pumps	51	PAR	Rotary Air Pumps	54	PE	Torc wrench pump	60
P	Double Acting Hand Pumps	48	PA	Single Acting Air Pumps	52	PU	Universal Motor Pumps	55	PE	3-Phase Electric Pumps	61
P57	Foot Pumps	50	PA	Double Acting Air Pumps	52	PE	1-Phase Electric Pumps	56	PG/PD	Gas/Diesel Engine Pumps	62

Pumps



Pages 48-67

H	General Purpose Cylinder Combinations	64	HLN	Lock Nut Cylinder Combinations	65
HF	Flat Body Cylinder Combinations	64	HU	Aluminum Cylinder Combinations	65
HC	Hollow Hole Cylinder Combinations	65	GT	1500 BAR	66
HL	Low Profile Cylinder Combinations	65			

Combo Kits



Pages 64-66

Flow Control Valves	68	Gauge Adapters	71	Pressure Switch	72	Hydraulic Couplers	73	Pressure control valve	74	Pump Mounted Valves	76
Manifolds	70	Hydraulic Oil	72	Foot Pedals	72	Hydraulic Hoses	73	Flow control Valve	74	Fittings	77
Pressure Gauges	71	External Pressure Adj	72	Coupler Dust Cover	72	Solenoid Valves	74	Directional Control Valves	75		

Valves & Accessories



Pages 68-77

Hydraulic Manual Press	78	Hydraulic Gear Pullers	82	Flange Spreaders	91	Mini Jacks	93	Maintenance kits	95
Hydraulic Electrical Press	79	Bolt Puller/King Pin Press	89	Spreaders	91	Toe Jacks	93	Impact Sockets	96
Manual Pullers	80	Pad Eye Tester	90	Hydraulic Nut Splitter with Case	92	Manual bottle jacks	94	Support Pads	97
Splitter	82	Valve Seat Puller	90	BVA Bag	92	Air operated bottle jacks	94		

Tools & Specials



Pages 78-97

Pumps / Cylinders Operation and Speed Chart	98	Safety Instructions	102	BVA in action	106
Selection worksheet	99	Maintaining Your Equipment	104	About BVA	107
BVA Cross Reference Chart	100	Hydraulic Formula Reference	104		

Cross-Reference & Engineering





Cylinder Matrix Chart

H | **C** | **30** | **06** | **T**

1 **2** **3** **4** **5**
Cylinder Cylinder Cylinder Cylinder Suffix
Type Options Capacity Stroke Code

1 - Cylinder Type

H Hydraulic Cylinder

2 - Cylinder Options

- C** S/A - Hollow Hole
- D** D/A - General Purpose
- DC** D/A - Hollow Hole
- DG** D/A - High Tonnage
- F** S/A - Flat Body
- G** S/A - Load Return High Tonnage
- L** S/A - Low Profile
- LN** S/A - Lock Nut
- LNF** S/A - Lock Nut Low Profile
- P** S/A - Pull
- PD** Precision Double Acting
- T** S/A - Threaded
- U** S/A - Aluminum
- UC** S/A - Aluminum Hollow Hole
- UDC** D/A - Aluminum Hollow Hole
- ULN** S/A - Aluminum Lock Nut

3 - Cylinder Capacity

US Short Tons		US Short Tons	
02	2, 2.5	75	75
04	4	100	100
05	5	150	150
09	9	160	160
10	10	200	200
12	12	250	250
15	15	300	300
16	16	400	400
20	20	500	500
25	25	600	600
30	30	700	700
50	50	800	800
55	55	1.000	1.000
60	60	1.500	1.500

4 - Cylinder Stroke

00	0.63"/16mm
01	1"/ 25 mm
02	2"/ 51 mm
04	4"/ 102 mm
05	5"/ 127 mm
06	6"/ 152 mm
08	8"/ 203 mm
10	10"/ 254mm
12	12"/ 305mm
13	13"/ 330mm
14	14"/ 356mm
18	18"/ 457mm
20	20"/ 508mm
24	24"/ 610mm
32	32"/ 813mm

5 - Suffix Code

- T** With internal Threads, HC Series only
- XT** No internal Threads, HC Series only
- B** Flat Body Cylinder Kit



Cylinder Accessories

See the assortment of accessories designed to work with our products. pg.44

Safety Practices

80% Good industry practice recommends not exceeding 80% of maximum rated capacities of all our products.

Safety Instructions

Visit our DO'S and DON'TS section to review the best methods of operation. Always be prepared. pg.102

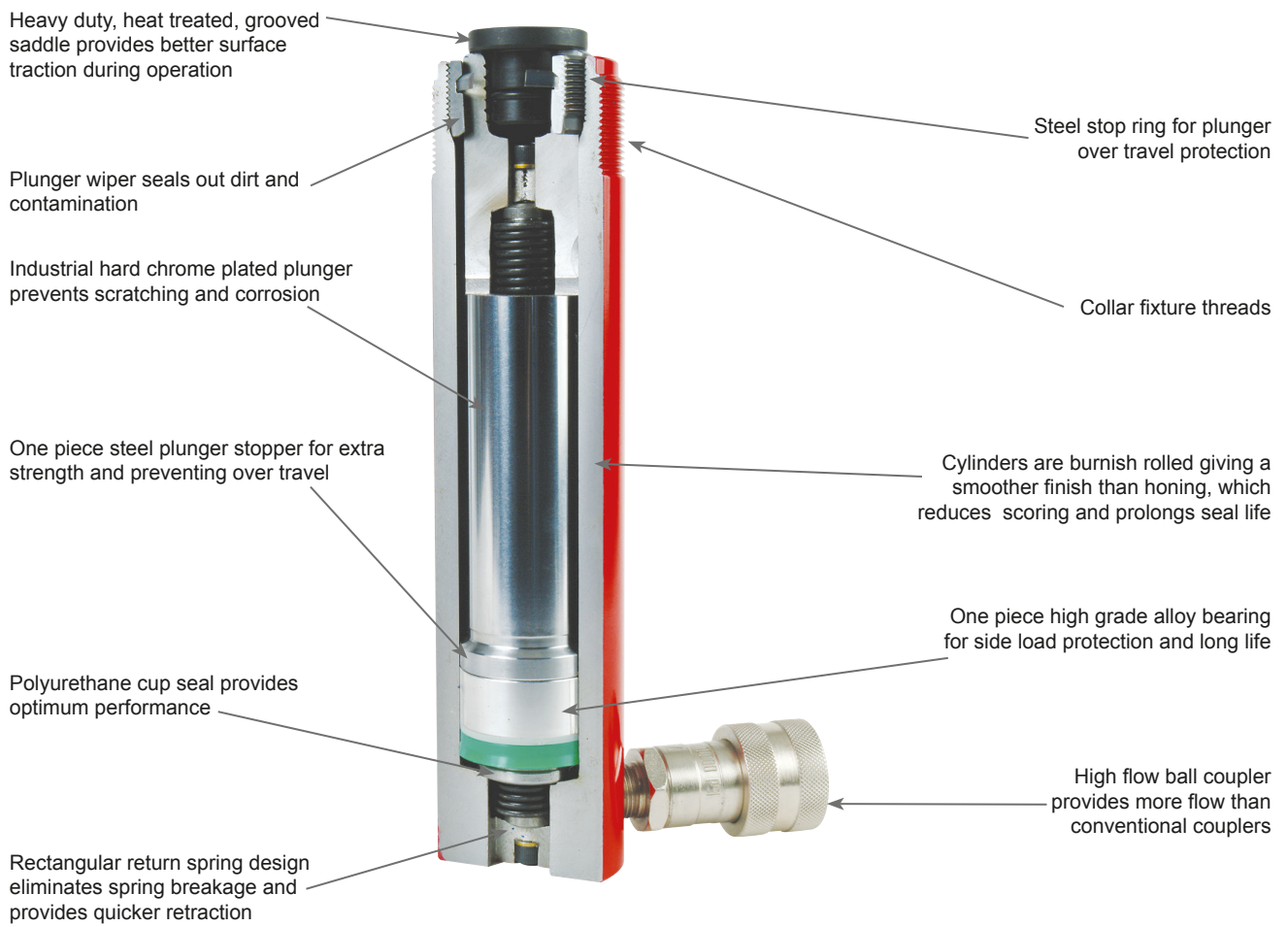

Cylinder Series	Cylinder Type		Max Capacity Range (Tonne)	Max Stroke Range (mm)	Page Number / Reference Image
H	Single Acting Cylinders		5-100	25-362	 6-9
HD	Double Acting Cylinders		10-100	155-461	 10-13
HL	Low Profile Cylinders		10-100	38-57	 14-15
HF	Flat Body Cylinders		5-150	16	 16-17
HLN	Lock Nut Cylinders		50-300	50-300	 18-19
HLNF	Low Profile Lock Nut Cylinders		60-250	45-50	 20
HG	High Tonnage Single Acting Cylinders		100-1000	182-1114	 22-25
HDG	High Tonnage Double Acting Cylinders		100-1000	50-300	 26-29
HC	Hollow Plunger Cylinders		12-100	8-155	 30-31
HDC	Double Acting Plunger Hole Cylinders		30-150	38-257	 32-33
HU	Aluminum Single Acting Cylinders		20-100	50-297	 34-35
HDU	Aluminum Double Acting Cylinders		20-30	50-150	 36-37
HULN	Lock Nut Aluminum Cylinders		30-150	50-254	 38
HUC	Single Acting Hollow Hole Aluminum Cylinders		30-60	75-152	 39
HUDC	Double Acting Aluminum Hollow Hole Cylinders		30-150	50-254	 40
HT	Threaded Cylinders		10-20	131-253	 41
HP	Pull Cylinders		2.5-10	127-141	 42
HPD	Precision Double Acting Cylinders		9-16	1.77-3.14	 43-44

Pumps Section	Page 42 ▶
Pumps-Cylinder Combo's	Page 60 ▶
Other	Page 62



Single Acting Cylinders

H Series - General Purpose, Spring Return

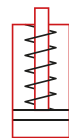

Capacity:

5 - 95 Tons

Stroke:

25 - 362 mm

Max. Operating Pressure:

700 BAR

Min. - Max. Height:

92 - 838 mm

*** Larger Tonnages**
For tonnages that exceed 100, please refer to our HG Section

22
pg



Single Acting Cylinder H1506 in the collapsed position with CB15 cylinder base for safety.

Single Acting Cylinder H5513 in the collapsed position ready to lift a load.

- Collar threads and base mounting holes for fixturing
- Hard chrome plated piston plunger protects against corrosion and damage
- Polyurethane U-Cup seals provide a sure seal and long life
- Solid one piece alloy steel body
- One piece aluminum alloy bearing protects against cylinder wall damage
- CH38F high flow coupler with dust cap is standard on all cylinders



Safety Practices

Good industry practice recommends not exceeding 80% of maximum rated capacities of all our products.

HU Series – Aluminum Cylinders



Aluminum cylinders make a great lightweight alternative being up to 60% lighter than comparable steel models.

34
pg

Quick Reference Guide

Cylinder Capacity	Stroke (mm)	Model Number	Collapsed Height (mm)	Oil Capacity (cc)	Weight (kg)
5 Tonne 44 kN	27	H0501	116	16	1.4
	78	H0503	169	50	1.5
	129	H0505	221	83	1.8
	181	H0507	272	116	2.1
	232	H0509	324	148	2.5
10 Tonne 99 kN	25	H1001	92	36	1.8
	51	H1002	123	74	2.3
	102	H1004	174	147	3.5
	155	H1006	250	218	4.3
	206	H1008	301	292	5.1
	257	H1010	352	366	5.9
	305	H1012	403	439	6.8
	356	H1014	450	515	7.6
15 Tonne 139 kN	25	H1501	124	50	3.1
	51	H1502	149	103	3.9
	101	H1504	200	205	5.0
	152	H1506	270	308	6.7
	203	H1508	321	411	7.8
	254	H1510	372	515	9.1
	305	H1512	423	618	10.2
	356	H1514	474	721	11.4
	407	H1516	529	824	12.8
25 Tonne 228 kN	26	H2501	143	86	5.5
	51	H2502	168	170	6.4
	102	H2504	219	339	8.2
	155	H2506	272	515	10.1
	206	H2508	323	684	11.9
	257	H2510	374	854	13.7
	310	H2512	426	1030	15.6
	362	H2514	476	1203	17.4
30 Tonne 287 kN	210	H3008	387	879	18.5
55 Tonne 487 kN	51	H5502	176	360	15.0
	103	H5504	227	730	18.6
	159	H5506*	283	1126	26.1
	260	H5510*	385	1844	30.6
	337	H5513*	461	2388	39.5
75 Tonne 718 kN	156	H7506*	285	1620	33.6
	333	H7513*	492	3459	55.3
95 Tonne 911 kN	51	H10002*	219	677	29.9
	168	H10006*	357	2229	57.6
	260	H10010*	449	3453	69.4
	356	H10014*	545	4721	81.6

See pages 8-9 for detailed specifications.

* Cylinder is equipped with carrying handle.



H Series

Cylinder Accessories
See the assortment of accessories designed to work with our products. pg 44

Combo Kits
Most cylinders are available in easy to order kits: Cylinder, Gauge, Couplers, Hose and Pump. pg 64

Related Product: Gauges
Reduce the risk of overloading your product by using a gauge. A variety of graduations and types to suit any need. pg 71

Safety Instructions
Visit our DO'S and DON'TS section to review the best methods of operation. Always be prepared. pg 102

High-Flow Couplers
High-Flow Coupler: CH38F is included on all models (except where specified).

Optional Tilt-Saddles
Saddles tilt to a 5% maximum to adjust to the load. Match up these saddles with the following cylinders:

SDT05	→	H05 Cylinders
SDT10	→	H10 Cylinders
SDT15	→	H15 Cylinders
SDT25	→	H25 Cylinders
SDT55	→	H55, H75, H100 Cylinders

pg 44

H

HD

HL

HF

HLN

HLNF

HG

HDG

HC

HDC

HU

HDU

HULN

HUC

HUCD

HT

HP

HPD

Cylinder accessories



Single Acting Cylinders

H Series - Spring Return

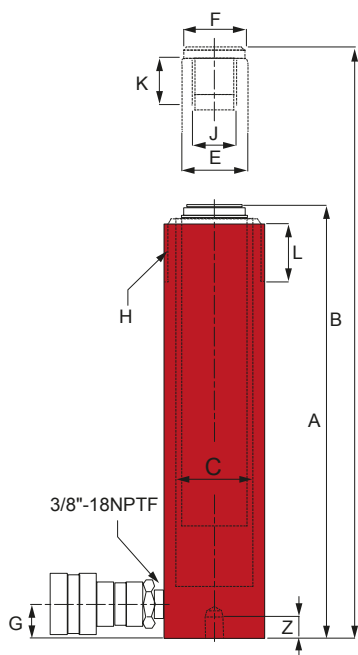
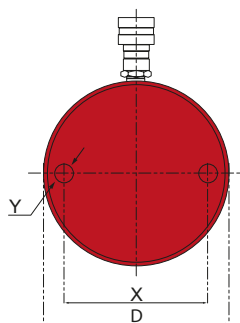

Cylinder Capacity	Stroke (mm)	Model Number	Cylinder Effective Area (cm ²)	Oil Capacity (cc)	Weight (kg)
5 Tonne 44 kN	27	H0501	6.5	16	1.4
	78	H0503	6.5	50	1.5
	129	H0505	6.5	83	1.8
	181	H0507	6.5	116	2.1
	232	H0509	6.5	148	2.5
10 Tonne 99 kN	25	H1001	14.4	36	1.8
	51	H1002	14.4	74	2.3
	102	H1004	14.4	147	3.5
	155	H1006	14.4	218	4.3
	206	H1008	14.4	292	5.1
	257	H1010	14.4	366	5.9
	305	H1012	14.4	439	6.8
15 Tonne 139 kN	25	H1501	20.3	50	3.1
	51	H1502	20.3	103	3.9
	101	H1504	20.3	205	5.0
	152	H1506	20.3	308	6.7
	203	H1508	20.3	411	7.8
	254	H1510	20.3	515	9.1
	305	H1512	20.3	618	10.2
	356	H1514	20.3	721	11.4
	407	H1516	20.3	824	12.8
25 Tonne 228 kN	26	H2501	33.2	86	5.5
	51	H2502	33.2	170	6.4
	102	H2504	33.2	339	8.2
	155	H2506	33.2	515	10.1
	206	H2508	33.2	684	11.9
	257	H2510	33.2	854	13.7
	310	H2512	33.2	1030	15.6
	362	H2514	33.2	1203	17.4
30 Tonne 287 kN	210	H3008	41.9	879	18.5
50 Tonne 487 kN	51	H5502	70.9	360	15.0
	103	H5504	70.9	730	18.6
	159	H5506*	70.9	1126	26.1
	260	H5510*	70.9	1844	30.6
	337	H5513*	70.9	2388	39.5
75 Tonne 713 kN	156	H7506*	103.9	1620	33.6
	333	H7513*	103.9	3459	55.3
95 Tonne 911 kN	51	H10002*	132.7	677	29.9
	168	H10006*	132.7	2229	57.6
	260	H10010*	132.7	3453	69.4
	356	H10014*	132.7	4721	81.6

* Cylinder is equipped with carrying handle.

Model Number	Collapsed Height A (mm)	Extended Height B (mm)	Cylinder Bore C (mm)	Outside Dia. D (mm)	Plunger Dia. E (mm)	Saddle Dia. F (mm)	Base to Inlet Port G (mm)	Collar Thread H	Collar Thread Length L (mm)	Plunger Internal Thread J	Plunger Thread Length K (mm)	Base Mounting Hole (mm)		
												Bolt Circle X	Thread Y	Thread Depth Z
H0501	116	142	29	38	25	25	20	1½"-16N	28	¾"-16UNF	16	25	¼"-20UNC	14
H0503	169	247	29	38	25	25	20	1½"-16N	28	¾"-16UNF	16	25	¼"-20UNC	14
H0505	221	350	29	38	25	25	20	1½"-16N	28	¾"-16UNF	16	25	¼"-20UNC	14
H0507	272	452	29	38	25	25	20	1½"-16N	28	¾"-16UNF	16	25	¼"-20UNC	14
H0509	324	552	28	38	25	25	20	1½"-16N	28	¾"-16UNF	16	25	¼"-20UNC	14
H1001	92	117	43	58	38	-	20	2¼"-14UN	30	-	6	40	5/16"-18UNC	14
H1002	123	174	43	58	38	35	20	2¼"-14UN	30	1"-8UNC	20	40	5/16"-18UNC	14
H1004	174	276	43	58	38	35	20	2¼"-14UN	30	1"-8UNC	20	40	5/16"-18UNC	14
H1006	250	401	43	58	38	35	20	2¼"-14UN	30	1"-8UNC	20	40	5/16"-18UNC	14
H1008	301	503	43	58	38	35	20	2¼"-14UN	30	1"-8UNC	20	40	5/16"-18UNC	14
H1010	352	605	43	58	38	35	20	2¼"-14UN	30	1"-8UNC	20	40	5/16"-18UNC	14
H1012	403	707	43	58	38	35	20	2¼"-14UN	30	1"-8UNC	20	40	5/16"-18UNC	14
H1014	450	806	43	58	38	35	20	2¼"-14UN	30	1"-8UNC	20	40	5/16"-18UNC	14
H1501	124	149	51	70	41	38	20	2¾"-16UN	30	1"-8UNC	25	48	3/8"-16UNC	13
H1502	149	200	51	70	41	38	20	2¾"-16UN	30	1"-8UNC	25	48	3/8"-16UNC	13
H1504	200	301	51	70	41	38	20	2¾"-16UN	30	1"-8UNC	25	48	3/8"-16UNC	13
H1506	270	422	51	70	41	38	25	2¾"-16UN	30	1"-8UNC	25	48	3/8"-16UNC	13
H1508	321	524	51	70	41	38	25	2¾"-16UN	30	1"-8UNC	25	48	3/8"-16UNC	13
H1510	372	626	51	70	41	38	25	2¾"-16UN	30	1"-8UNC	25	48	3/8"-16UNC	13
H1512	423	728	51	70	41	38	25	2¾"-16UN	30	1"-8UNC	25	48	3/8"-16UNC	13
H1514	474	830	51	70	41	38	25	2¾"-16UN	30	1"-8UNC	25	48	3/8"-16UNC	13
H1516	529	936	51	70	41	38	25	2¾"-16UN	30	1"-8UNC	25	48	3/8"-16UNC	13
H2501	143	169	65	85	57	50	25	3½"-12N	49	1½"-16UNC	30	59	½"-13UNC	19
H2502	168	219	65	85	57	50	25	3½"-12N	49	1½"-16UNC	30	59	½"-13UNC	19
H2504	219	321	65	85	57	50	25	3½"-12N	49	1½"-16UNC	30	59	½"-13UNC	19
H2506	272	427	65	85	57	50	25	3½"-12N	49	1½"-16UNC	30	59	½"-13UNC	19
H2508	323	529	65	85	57	50	25	3½"-12N	49	1½"-16UNC	30	59	½"-13UNC	19
H2510	374	631	65	85	57	50	25	3½"-12N	49	1½"-16UNC	30	59	½"-13UNC	19
H2512	426	736	65	85	57	50	25	3½"-12N	49	1½"-16UNC	30	59	½"-13UNC	19
H2514	476	838	65	85	57	50	25	3½"-12N	49	1½"-16UNC	30	59	½"-13UNC	19
H3008	387	597	73	102	57	50	50	3½"-12UN	49	1½"-16UNC	30	56	½"-13UNC	19
H5502	176	227	95	127	80	70	31	5"-12UN	55	-	-	95	½"-13UNC	19
H5504	227	330	95	127	80	70	31	5"-12UN	55	-	-	95	½"-13UNC	19
H5506*	283	442	95	127	80	70	31	5"-12UN	55	-	-	95	½"-13UNC	19
H5510*	385	645	95	127	80	70	31	5"-12UN	55	-	-	95	½"-13UNC	19
H5513*	461	798	95	127	80	70	31	5"-12UN	55	-	-	95	½"-13UNC	19
H7506*	285	466	115	147	95	70	30	5¾"-12UN	45	-	-	100	¾"-10UNC	22
H7513*	492	825	115	147	95	70	30	5¾"-12UN	45	-	-	100	¾"-10UNC	22
H10002*	219	270	130	159	105	70	38	6¼"-12UN	55	-	-	-	-	-
H10006*	357	525	130	177	105	70	40	6½"-12UN	45	-	-	140	¾"-10UNC	25
H10010*	449	709	130	177	105	70	40	6½"-12UN	45	-	-	140	¾"-10UNC	25
H10014*	545	901	130	177	105	70	40	6½"-12UN	45	-	-	140	¾"-10UNC	25

* Cylinder is equipped with carrying handle.



Double Acting Cylinders

HD Series - General Purpose



Capacity:

10 - 100 Tonnes

Stroke:

155 - 461 mm

Pressure:

700 BAR

Min. - Max. Height:

331 - 1269 mm



HD10006



HD3008

- Plunger wiper seals out dirt and contamination
- High strength steel construction from gun drilled solid bar
- High flow 3/8" NPTF female couplers
- One piece high grade alloy bearing for side load protection and long life
- Ideal for pushing and pulling
- Maximum working pressure: 10,000 psi / 700 bar
- Threaded cylinders, removable saddle, thicker cylinder walls
- Retract under hydraulic power for faster operation



Safety Practices

Good industry practice recommends not exceeding 80% of maximum rated capacities of all our products.



HD cylinders can be used in pushing and pulling applications. In this photo, we see a HD cylinder set up for a pull application using a Plunger Clevis cylinder accessory



HD5513

HD7513



HD Series

HDU Series – Aluminum Cylinders



Aluminum cylinders make a great lightweight alternative being up to 60% lighter than comparable steel models.

36
pg

Cylinder Accessories



See the assortment of accessories designed to work with our products.

44
pg

Combo Kits



Most cylinders are available in easy to order kits: Cylinder, Gauge, Couplers, Hose and Pump.

64
pg

Related Product: Gauges



Reduce the risk of overloading your product by using a gauge. A variety of graduations and types to suit any need.

71
pg

Safety Instructions

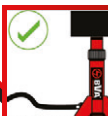

Visit our DO'S and DON'TS section to review the best methods of operation. Always be prepared.

102
pg

High-Flow Couplers

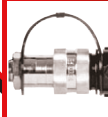

High-Flow Coupler: CH38F is included on all models (except where specified).

Relief Valve

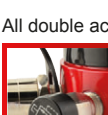

All double acting cylinders are equipped with a pressure relief valve located next to the retract port. These pressure relief valves help prevent cylinder over pressurization on the return port side of the cylinder.

Quick Selection Guide

Cylinder Capacity	Stroke (mm)	Model Number	Collapsed Height (mm)	Oil Capacity		Weight (kg)
				Push (cc)	Pull (cc)	
10 Tonne 100/33 kN	255	HD1010	409	367	122	12.1
	304	HD1012	458	438	146	13.6
30 Tonne 288/141 kN	207	HD3008	389	867	426	19.5
	368	HD3014	550	1542	758	27.5
50 Tonne 486/141 kN	157	HD5506*	331	1113	323	32.0
	335	HD5513*	509	2375	690	47.2
	511	HD5520*	733	3623	1053	66.3
75 Tonne 713/227 kN	155	HD7506*	348	1608	511	42.5
	333	HD7513*	526	3457	1099	62.1
100 Tonne 911/424 kN	167	HD10006*	357	2216	1032	62.9
	257	HD10010*	449	3413	1591	76.7
	333	HD10013*	524	4419	2058	87.8
	461	HD10018*	687	6117	2849	112.6
150 Tonne 1348/634	156	HD15006*	386	3056	1439	78.4
	334	HD15013*	584	6546	3082	111.3

* Are equipped with carrying handles.

H

HD

HL

HF

HLN

HLNF

HG

HDG

HC

HDC

HU

HDU

HULN

HUC

HUDC

HT

HP

HPD

Cylinder accessories



Double Acting Cylinders

HD Series - General Purpose

Cylinder Accessories
See the assortment of accessories designed to work with our products. 44
pg

Related Product: Gauges
Reduce the risk of overloading your product by using a gauge. A variety of graduations and types to suit any need. 71
pg

Combo Kits
Most cylinders are available in easy to order kits: Cylinder, Gauge, Couplers, Hose and Pump. 64
pg

Safety Instructions
Visit our DO'S and DON'TS section to review the best methods of operation. Always be prepared. 102
pg



Cylinder Capacity	Stroke (mm)	Model Number	Maximum Cylinder Capacity		Cylinder Effective Area		Oil Capacity		Weight (kg)	Collapsed Height A (mm)	Extended Height B (mm)	Cylinder Bore Dia. C (mm)
			Push (Tonne)	Pull (Tonne)	Push (cm ²)	Pull (cm ²)	Push (cc)	Pull (cc)				
10 Tonne 100/33 kN	255	HD1010	11.4	3.8	14.5	4.8	367	122	12.1	409	665	43
	304	HD1012	11.4	3.8	14.5	4.8	438	146	13.6	458	762	43
30 Tonne 288/141 kN	207	HD3008	32.9	16.2	41.9	20.6	867	426	19.5	389	596	73
	368	HD3014	32.9	16.2	41.9	20.6	1542	758	27.5	550	918	73
50 Tonne 486/141 kN	157	HD5506*	55.7	16.2	70.9	20.6	1113	323	32.0	331	488	95
	335	HD5513*	55.7	16.2	70.9	20.6	2375	690	47.2	509	844	95
	511	HD5520*	55.7	16.2	70.9	20.6	3623	1053	66.3	733	1269	95
75 Tonne 713/227 kN	155	HD7506*	81.7	25.9	103.8	33	1608	511	42.5	348	503	115
	333	HD7513*	81.7	25.9	103.8	33	3457	1099	62.1	526	859	115
100 Tonne 911/424 kN	167	HD10006*	104.4	48.6	132.7	61.8	2216	1032	62.9	357	524	130
	257	HD10010*	104.4	48.6	132.7	61.8	3413	1591	76.7	449	706	130
	333	HD10013*	104.4	48.6	132.7	61.8	4419	2058	87.8	524	857	130
	461	HD10018*	104.4	48.6	132.7	61.8	6117	2849	112.6	687	1148	130
150 Tonne 1348/634	156	HD15006*	140.1	66	196.3	92.4	3065	1439	78.4	386	542	158
	334	HD15013*	140.1	66	196.3	92.4	6546	3082	14.3	564	898	158

* Are equipped with carrying handles.

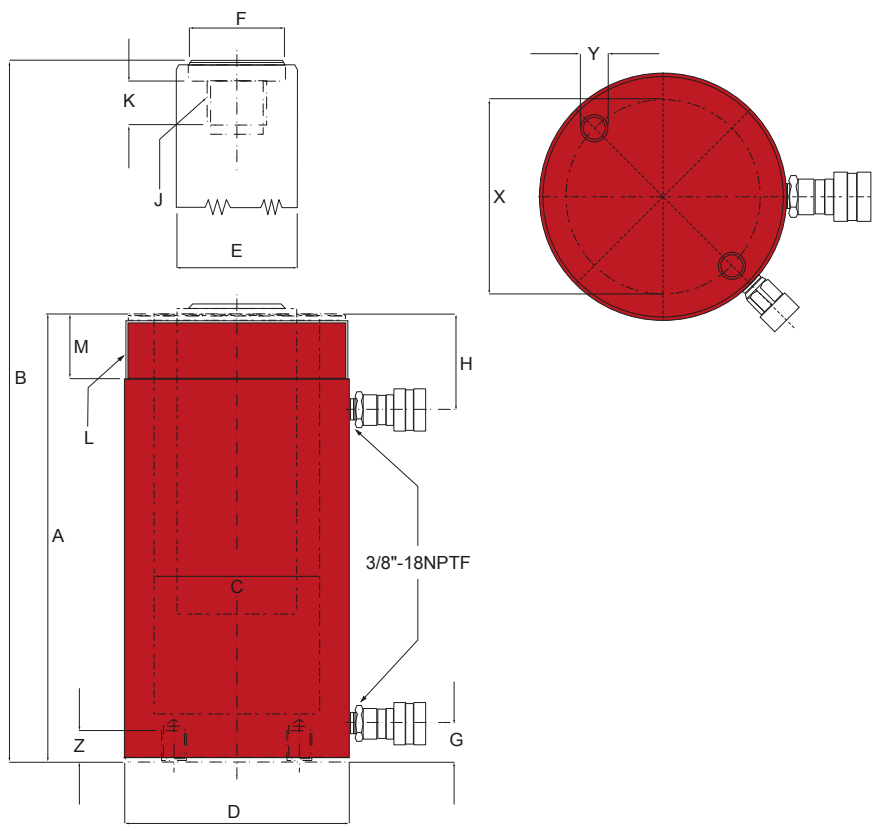

HD Series

80% **Safety Practices**
 Good industry practice recommends not exceeding 80% of maximum rated capacities of all our products.

Relief Valve
 All double acting cylinders are equipped with a pressure relief valve located next to the retract port. These pressure relief valves help prevent cylinder over pressurization on the return port side of the cylinder.

High-Flow Couplers
 High-Flow Coupler: CH38F is included on all models (except where specified).

Model Number	Outside Dia. D (mm)	Plunger Dia. E (mm)	Saddle Dia. F (mm)	Base to Inlet Port G (mm)	Top to Return Port H (mm)	Plunger Internal Thread J	Plunger Thread Length K (mm)	Collar Thread L	Collar Thread Length M (mm)	Base Mounting Hole		
										Bolt Circle X (mm)	Thread Y	Thread Depth Z (mm)
HD1010	73	35	35	36	53	1"-8UNC	25	2¼"-14UN	26	33	⅝"-18UNC	15
HD1012	73	35	35	36	53	1"-8UNC	25	2¼"-14UN	26	33	⅝"-18UNC	15
HD3008	101	54	50	42	74	1½"-16UN	25	3⅝"-12UN	49	56	½"-13UNC	18
HD3014	101	54	50	42	74	1½"-16UN	25	3⅝"-12UN	49	56	½"-13UNC	18
HD5506*	127	80	70	29	73	1"-12UNF	25	5"-12UN	44	95	½"-13UNC	18
HD5513*	127	80	70	29	73	1"-12UNF	25	5"-12UN	44	95	½"-13UNC	18
HD5520*	127	80	70	29	73	1"-12UNF	25	5"-12UN	44	95	½"-13UNC	18
HD7506*	146	95	70	30	71	1"-12UNF	38	5¾"-12UN	38	102	¾"-10UNC	23
HD7513*	146	95	70	30	71	1"-12UNF	38	5¾"-12UN	38	102	¾"-10UNC	23
HD10006*	177	95	75	31	75	1¾"-12UN	35	6⅞"-12N	51	139	¾"-10UNC	25
HD10010*	177	95	75	31	75	1¾"-12UN	38	6⅞"-12N	51	139	¾"-10UNC	25
HD10013*	177	95	75	31	75	1¾"-12UN	35	6⅞"-12UN	51	139	¾"-10UNC	25
HD10018*	177	95	75	38	75	1¾"-12UN	35	6⅞"-12UN	51	139	¾"-10UNC	25
HD15006*	203	115	115	50	84	3⅝"-16UN	36	8"-12UN	60	159	¾"-16UNF	25
HD15013*	203	115	115	50	84	3⅝"-16UN	36	8"-12UN	60	159	¾"-16UNF	25

* Are equipped with carrying handles.

- H
- HD
- HL
- HF
- HLN
- HLNF
- HG
- HDG
- HC
- HDC
- HU
- HDU
- HULN
- HUC
- HUDC
- HT
- HP
- HPD
- Cylinder accessories



Low Profile Cylinders

HL Series - Low Clearance Lifting

- Compact design for use in confined spaces.
- Plunger wiper helps seal out dirt and contamination.
- Specially designed return spring provides quick retraction and extends the life of the spring.
- Hard chrome plated plunger helps prevent scratching and corrosion.
- Plunger end is grooved to reduce load slippage.
- Includes high flow coupler and dust cap.
- HL1001, HL2002, and HL3002 coupler is tilted 5° for added clearance.

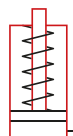

HL Series

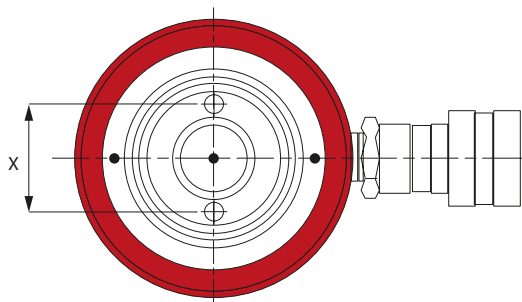
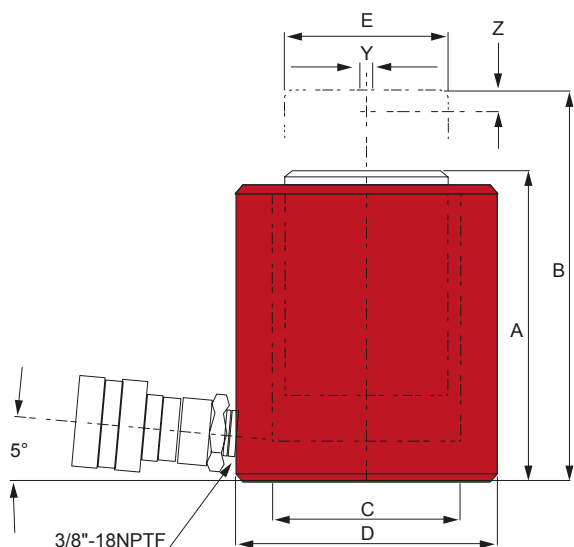

Low profile cylinders are great for confined spaces.

Cylinder Capacity	Stroke (mm)	Model Number	Cylinder Effective Area (cm ²)	Oil Capacity (cc)	Weight (kg)
10 Tonne 104 kN	38	HL1001	15.2	58	2.6
20 Tonne 194 kN	44	HL2002	28.2	125	5.0
30 Tonne 288 kN	62	HL3002	41.9	260	6.8
45 Tonne 437 kN	60	HL5002	63.7	382	9.9
90 Tonne 870 kN	57	HL10002	126.7	722	20.6



Model Number	Collapsed Height A (mm)	Extended Height B (mm)	Cylinder Bore Diameter C (mm)	Outside Diameter D (mm)	Plunger Diameter E (mm)	Plunger Mounting		
						Bolt Circle X (mm)	Thread Y	Thread Depth Z (mm)
HL1001	89	126	44	70	38	26	M4	8
HL2002	99	144	60	92	51	40	M5	8
HL3002	117	179	73	102	64	40	M5	8
HL5002	122	182	90	124	70	40	M5	8
HL10002	141	198	127	165	90	56	M8	3

Low Profile Cylinders Combo Kit

Low Clearance Lifting



▲ Press truck wheel from nave with the mini-press. Fits between the chassis and wheel.

- Compact design for use in confined spaces.
- Ideal for pushing applications.
- Plunger wiper helps seal out dirt and contamination.
- Return spring ensures a quick retraction and extends the life of the spring.
- Industrial hard chrome plated plunger helps prevent scratching and corrosion.
- Includes stackable 1", 2", and 3" aluminum adapters that conveniently snap into the base of the plunger.
- Includes high flow CH38F coupler and dust cap.
- Convenient storage case.

HL Series



80% **Safety Practices**

Good industry practice recommends not exceeding 80% of maximum rated capacities of all our products.

Related Product: Hoses

We offer a variety of hoses, fittings, lengths and materials.

pg 73

High-Flow Couplers

High-Flow Coupler: CH38F is included on all models (except where specified).

Cylinder Capacity	Model Number	Stroke (mm)	Cylinder Effective Area (cm ²)	Collapsed Height (mm)	Extended Height w/o adapter (mm)	Internal Pressure at Capacity (BAR)	Cylinder Housing Diameter (mm)	Plunger Diameter (mm)	Weight (kg)
10 Tonne 106 kN	HL1001D	38	15.16	88	126	0.59	70	38	4.5



SDTL50



SDTL100



SDTL10

Bolt-On Tilt Saddles

Bolt-On tilt saddles are designed specifically for use with the HL Series Low Profile Cylinders and Low Profile Cylinder Kit. These saddles provide a max. 5° tilt for uneven loads.

Model Number	Height (mm)	Description
SDTL10	21	HL1001 Cylinder Kit
SDTL50	29	HL2002 / HL3002 / HL5002 Cylinder
SDTL100	35	HL10002 Cylinder

- HL
- HD
- HL
- HF
- HLN
- HLNF
- HG
- HGD
- HC
- HDC
- HU
- HDU
- HULN
- HUC
- HUDC
- HT
- HP
- HPD

Cylinder accessories



Flat Body Cylinders

HF series - Extremely Low Lifting

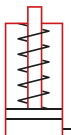

- Extremely low collapsed height for applications with minimal clearance at the lift point.
- Maximum working pressure 10,000 psi / 700 bar.
- HF0503 and HF0503B include a 3/8" regular flow coupler (CR38F).

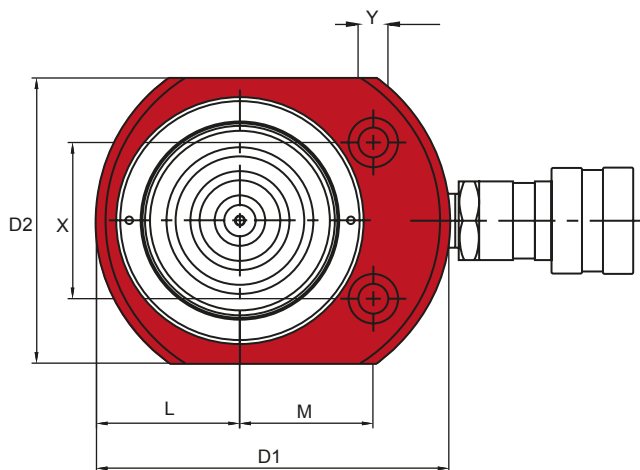

HF Series

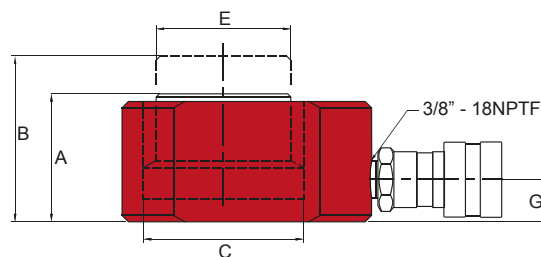

HF5006 in the collapsed position ready to lift a load with a PA1500 foot pump.



Cylinder Capacity	Stroke (mm)	Model Number	Cylinder Effective Area (cm ²)	Oil Capacity (cc)	Weight (kg)
5 Tonne / 49 kN	16	HF0500	7.1	11	0.9
5 Tonne / 49 kN	6	HF0503*	7.1	4	0.6
10 Tonne / 104 kN	11	HF1005	15.2	17	1.5
20 Tonne / 194 kN	11	HF2005	28.3	31	2.7
30 Tonne / 288 kN	13	HF3005	41.9	54	4.4
45 Tonne / 437 kN	16	HF5006	63.6	102	6.8
75 Tonne / 726 kN	16	HF7506	103.9	166	11.5
90 Tonne / 870 kN	16	HF10006	126.7	203	14.3
150 Tonne / 1359 kN	16	HF15006	197.9	316	24.2

Model Number	Collapsed Height A (mm)	Extended Height B (mm)	Cylinder Bore Dia. C (mm)	Outside Dia. D1 x D2 D (mm)	Plunger Dia. E (mm)	Base to Inlet Port G (mm)	Plunger to Base L (mm)	Plunger to Mtg. Hole M (mm)	Hole Pitch X (mm)	Hole Dia. Y (mm)	Counter Bore Dia. (mm)	Counter Bore Depth (mm)
HF0500	41	57	30	60x40	25	19	20	22	28	5	10	6
HF0503*	32	38	30	61x41	25	18	20	22	28	5	8	4
HF1005	43	54	44	84x56	38	20	28	34	37	7	11	8
HF2005	51	62	60	102x76	51	19	39	40	49	10	15	10
HF3005	59	72	73	117x97	64	20	48	44	52	10	16	11
HF5006	67	83	90	140x114	70	20	57	54	67	11	19	13
HF7506	80	96	115	165x140	90	20	70	67	76	13	21	14
HF10006	86	102	127	177x152	90	20	76	75	76	13	21	14
HF15006	100	116	159	215x190	118	24	3.75	95	117	13	21	14

*HF0503 is fitted with the CR38F

Flat Body Cylinder Kits

HF Series - Kits



- Various height stackable magnetic adapters eliminate dangerous cribbing.
- Convenient carrying case.
- Magnetic adapters are stackable.
- U.S. Patent No.7,237,762 B2.

HF Series

80%

Safety Practices

Good industry practice recommends not exceeding 80% of maximum rated capacities of all our products.

High-Flow Couplers

High-Flow Coupler: CH38F is included on all models (except where specified)

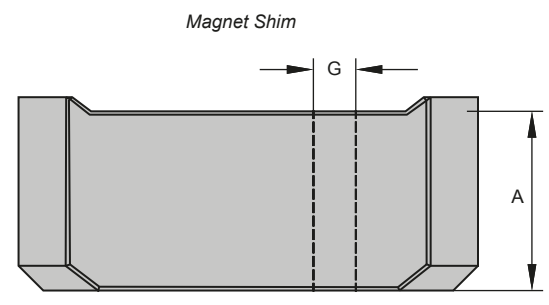
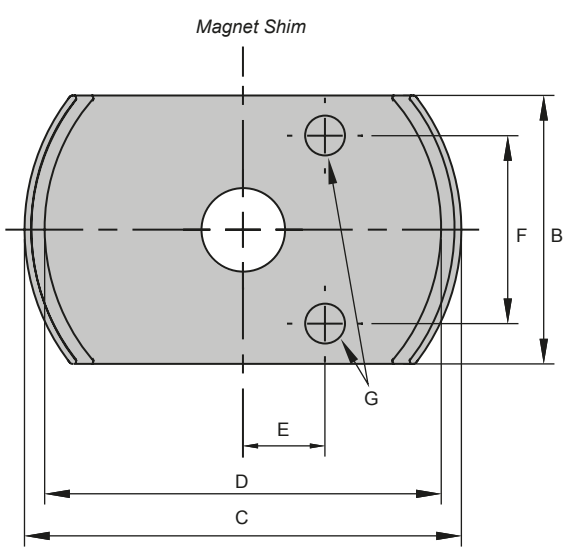

Cylinder Capacity	Stroke (mm)	Model Number	Cylinder Model	Oil Capacity (cc)	Collapsed Height (mm)	Weight (kg)	Adapter Dimensions						
							A (mm)	B (mm)	C (mm)	D (mm)	E (mm)	F (mm)	G (mm)
5 Tonne 49 kN	6	HF0503B**	HF0503	4	32	2.5	4	41	65	59	12	28	6
							11	41	65	59	12	28	6
							23	41	65	59	12	28	6
							30	41	65	59	12	28	6
10 Tonne 104 kN	11	HF1005B	HF1005	17	43	4.2	10	56	90	82	21	37	7
							20	56	90	82	-	-	-
							40	56	90	82	-	-	-
20 Tonne 194 kN	11	HF2005B	HF2005	31	51	6.8	10	76	108	100	27	49	10
							20	76	108	100	-	-	-
							40	76	108	100	-	-	-
30 Tonne 288 kN	13	HF3005B	HF3005	54	59	9.5	10	95	121	113	34	52	10
							20	95	121	113	-	-	-
							40	95	121	113	-	-	-
45 Tonne 437 kN	16	HF5006B	HF5006	102	67	14.7	10	114	150	141	41	67	11
							20	114	150	141	-	-	-
							40	114	150	141	-	-	-

**HF0503B is fitted with the coupler CR38F

- H
- HD
- HL
- HF
- HLN
- HLNF
- HG
- HDG
- HC
- HDC
- HU
- HDU
- HULN
- HUC
- HUDC
- HT
- HP
- HPD
- Cylinder accessories



Lock Nut Cylinders

HLN Series - Heavy Lifting with Mechanical Lock Nut

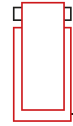

Capacity:
50 - 300 Tonnes

Stroke:
50 - 300 mm

Max. Operating Pressure:
700 BAR

Min. - Max. Height:
165 - 845 mm
10% sideload @ 80% capacity

- Single acting cylinder with mechanical safety lock nut.
- Designed to support loads without hydraulic pressure.
- Overflow port prevents cylinders from over travel.
- Load return.
- Solid steel cylinder body.
- Electroless nickel plated plunger to resist corrosion and rust.
- Maximum working pressure: 10. 000 psi / 700 bar.

Cylinder Capacity	Stroke (mm)	Model Number	Cylinder Effective Area (cm ²)	Oil Capacity (cc)	Weight (kg)
50 Tonne 487 kN	50	HLN5502	70.9	355	15.4
	100	HLN5504	70.9	709	20.4
	150	HLN5506	70.9	1064	24.9
	200	HLN5508	70.9	1418	29.9
	250	HLN5510	70.9	1773	34.9
	300	HLN5512	70.9	2127	39.5
100 Tonne 911 kN	50	HLN10002	132.7	664	30.4
	100	HLN10004	132.7	1327	39.0
	150	HLN10006	132.7	1991	47.2
	200	HLN10008	132.7	2654	55.8
	250	HLN10010	132.7	3318	64.0
150 Tonne 1380 kN	50	HLN15002	201	1006	52.6
	100	HLN15004	201	2012	65.8
	150	HLN15006	201	3018	78.9
	200	HLN15008	201	4019	91.6
	250	HLN15010	201	5025	104.8
	300	HLN15012	201	6031	117.5
200 Tonne 1816 kN	50	HLN20002	264.5	1322	82.1
	100	HLN20004	264.5	2645	98.9
	150	HLN20006	264.5	3966	116.1
	200	HLN20008	264.5	5293	132.9
	250	HLN20010	264.5	6612	150.1
	300	HLN20012	264.5	7934	166.9
250 Tonne 2493 kN	50	HLN25002	363.1	1815	114.8
	150	HLN25006	363.1	5446	161.5
	300	HLN25012	363.1	10891	231.3
300 Tonne 3119 kN	50	HLN30002	454.3	2271	171.9
	150	HLN30006	454.3	6814	231.3
	300	HLN30012	454.3	13628	320.2

Optional Tilt Saddles

SDT55	→	HLN55, HLN100 Cylinders
SDT200	→	HLN150, HLN200 Cylinders
SDT250	→	HLN250
SDT300	→	HLN300



Saddles tilt to a 5° max to adjust to the load.

45°

(42) HLN5508 lock nut cylinders lifting the Jordan Bridge in Chesapeake, VA.



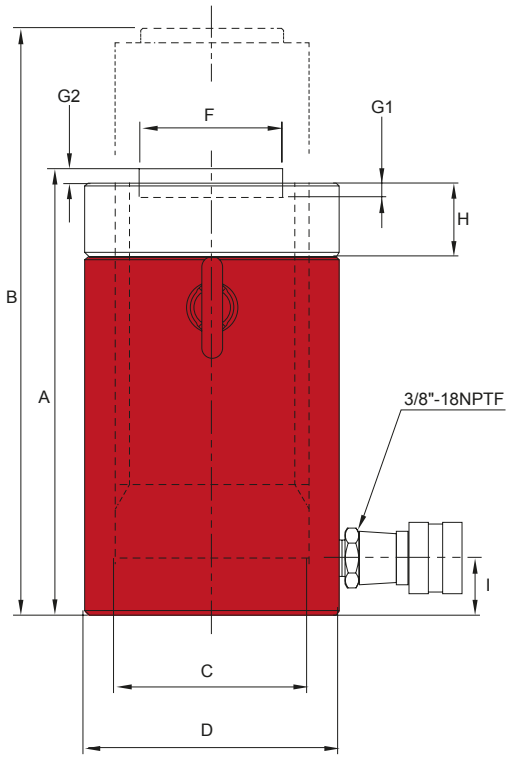

HLN Series

Safety Color Band

BVA Lock nut cylinders are equipped with a yellow safety band. Do not extend the ram beyond this point as it may result in a loss of hydraulic oil and damage to the cylinder and/or load.

Safety Practices

Good industry practice recommends not exceeding 80% of maximum rated capacities of all our products.

Model Number	Collapsed Height A (mm)	Extended Height B (mm)	Cylinder Bore Diameter C (mm)	Outside Diameter D (mm)	Saddle Diameter F (mm)	Depth of Plunger Hole G1 (mm)	Saddle Protrusion From Plunger G2 (mm)	Lock Nut Length H (mm)	Base to Inlet Port I (mm)
HLN5502	165	213	94	124	71	13	2	36	28
HLN5504	213	315	94	124	71	13	2	36	28
HLN5506	264	414	94	124	71	13	2	36	28
HLN5508	315	513	94	124	71	13	2	36	28
HLN5510	363	615	94	124	71	13	2	36	28
HLN5512	414	714	94	124	71	13	2	36	28
HLN10002	188	236	130	165	71	13	2	46	28
HLN10004	236	338	130	165	71	13	2	46	28
HLN10006	287	437	130	165	71	13	2	46	28
HLN10008	338	536	130	165	71	13	2	46	28
HLN10010	386	638	130	165	71	13	2	46	28
HLN10012	437	737	130	165	71	13	2	46	28
HLN15002	209	259	160	205	130	25	2	44	39
HLN15004	259	359	160	205	130	25	2	44	39
HLN15006	309	459	160	205	130	25	2	44	39
HLN15008	359	559	160	205	130	25	2	44	39
HLN15010	409	659	160	205	130	25	2	44	39
HLN15012	459	759	160	205	130	25	2	44	39
HLN20002	243	292	183	235	130	25	2	50	50
HLN20004	293	393	183	235	130	25	2	50	50
HLN20006	343	495	183	235	130	25	2	50	50
HLN20008	394	594	183	235	130	25	2	50	50
HLN20010	442	693	183	235	130	25	2	50	50
HLN20012	493	793	183	235	130	25	2	50	50
HLN25002	249	299	215	275	150	25	2	56	50
HLN25006	349	499	215	275	150	25	2	56	50
HLN25012	499	799	215	275	150	25	2	56	50
HLN30002	295	345	241	310	139	25	5	60	59
HLN30006	395	545	241	310	139	25	5	60	59
HLN30012	545	845	241	310	139	25	5	60	59

- H
- HD
- HL
- HF
- HLN
- HLNF
- HG
- HDG
- HC
- HDC
- HU
- HDU
- HULN
- HUC
- HUUC
- HT
- HP
- HPD
- Cylinder accessories



Low Profile Lock Nut Cylinders

HLNF Series - Low Clearance Lifting with Mechanical Lock Nut

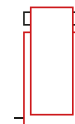

- Single acting cylinder with mechanical safety lock nut.
- Designed to support loads without hydraulic pressure.
- Low profile for confined spaces.
- 5° tilting saddle is standard.
- Maximum working pressure: 10,000 psi/700 bar.
- Equipped with CH38F high flow coupler.
- Load Return.
- Able to withstand 10% Side load @ 80% stroke



Related Product: Gauges
Reduce the risk of overloading your product by using a gauge. A variety of graduations and types to suit any need. 71
pg



Safety Color Band
BVA Lock nut cylinders are equipped with a yellow safety band. Do not extend the ram beyond this point as it may result in a loss of hydraulic oil and damage to the cylinder and/or load.



Safety Instructions
Visit our DO'S and DON'TS section to review the best methods of operation. Always be prepared. 102
pg



Cylinder Capacity	Stroke (mm)	Model Number	Cylinder Effective Area (cm ²)	Oil Capacity (cc)	Weight (kg)
60 Tonne 594 kN	50	HLNF6002	86.6	433	14.2
100 Tonne 995 kN	50	HLNF10002	144.9	725	24.5
160 Tonne 1573 kN	45	HLNF16002	229.1	1031	41.3
200 Tonne 1947 kN	45	HLNF20002	283.6	1276	53.8
250 Tonne 2493 kN	45	HLNF25002	363.1	1634	70.1
400 Tonne 3844 kN	45	HLNF40002	559.9	2519.6	128.9





HLNF Series

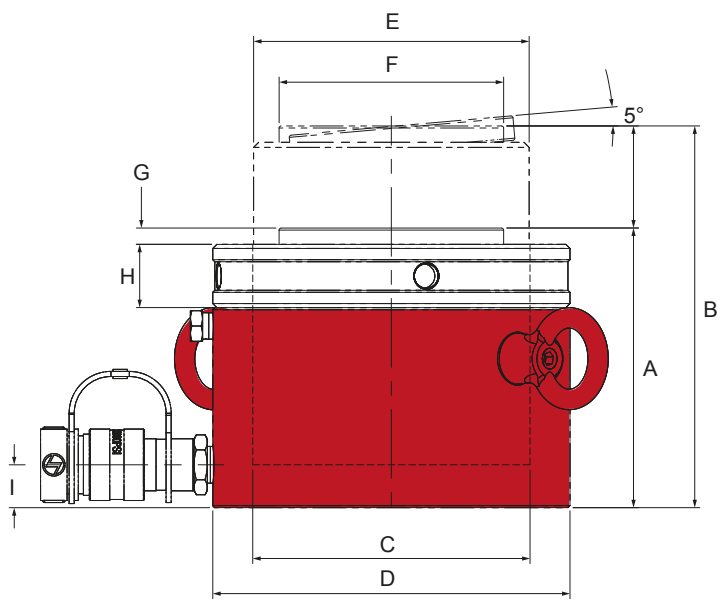
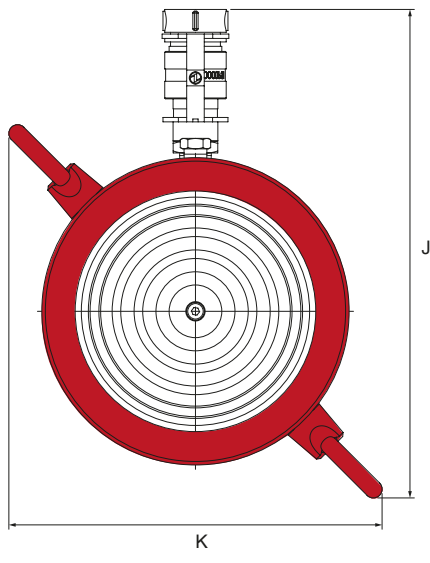

Safety Color Band



BVA Lock nut cylinders are equipped with a yellow safety band. Do not extend the ram beyond this point as it may result in a loss of hydraulic oil and damage to the cylinder and/or load.

80% Safety Practices



Good industry practice recommends not exceeding 80% of maximum rated capacities of all our products.

Model Number	Collapsed Height A (mm)	Extended Height B (mm)	Cylinder Bore Dia. C (mm)	Outside Dia. D (mm)	Plunger Outside Thread E	Saddle Dia. F (mm)	Saddle Protrusion From Plunger G (mm)	Lock Nut Length H (mm)	Base to Inlet Port I (mm)	Coupler to Eyelet J (mm)	Eyelet to Eyelet K (mm)
HLNF6002	125	175	105	140	TW105-4N	82	6	28	19	248	188
HLNF10002	137	187	136	175	TW135-4N	110	8	31	21	278	213
HLNF16002	148	193	171	220	TW170-4N	148	9	40	27	316	244
HLNF20002	155	200	190	245	TW190-4N	160	10	43	30	338	262
HLNF25002	159	204	215	275	TW215-4N	185	11	44	32	363	283
HLNF40002	178	223	267	350	TR267-6	250	11	55	37	-	454

- H
- HD
- HL
- HF
- HLN
- HLNF**
- HG
- HDG
- HC
- HDC
- HU
- HDU
- HULN
- HUC
- HUCD
- HT
- HP
- HPD
- Cylinder accessories



High Tonnage Single Acting Cylinders

HG series - Heavy Lifting, Load Return



HG10004

HG15006

HG20002

Capacity:

95 - 1000 Tonnes

Stroke:

50 - 300 mm

Max. Operating Pressure:

700 BAR

Min. - Max. Height:

182 - 1114 mm

10% side load @ max stroke



Flow Control Valves

Control the speed of your cylinder by adding a flow control valve.

pg 74



Related Product: Hoses

We offer a variety of hoses, fittings, lengths and materials.

pg 73

Gas/Diesel Engine Pumps

These HDG cylinders pair up well with a Gas or Diesel Engine pump. We offer a variety of different flow rates, motor sizes and reservoir sizes on our gas/diesel engine pumps. Contact your local BVA dealer for more details.



- Gas engine pump will provide 700 BAR hydraulic force at remote locations.
- Industrial grade 5.5 hp. (4.1 kN) Honda gas engine or 4.6 hp. (3.5 kN) HATZ diesel engine.
- Ideal for applications where electricity isn't easily accessible.
- Two speed pump designed for rapid cylinder advance.
- Gas pump features a sturdy protective roll cage for use in the toughest environments.
- Optional electric start with Diesel Engine.

Electric Motor Pumps

These HG cylinders pair up well with Electric Motor pumps. We offer a variety of different flow rates and motor sizes. Contact your local BVA dealer for more details.



- Meets OSHA regulations for sound (80dBA).
- Two speed pump designed for rapid cylinder advance.
- Internal filter screens contamination to prevent pump damage.
- All units are wired as 230 VAC 50 Hz; Optional wiring 120 VAC 50Hz.
- 100% Duty Cycle TEFC motors.
- All hand pendants are wired at 24VAC for safety.
- Full load starting capability.

Quick Reference Guide

Cylinder Capacity	Stroke (mm)	Model Number	Collapsed Height (mm)	Oil Capacity (cc)	Weight (kg)
95 Tonne 911 kN	50	HG10002	182	664	27.7
	100	HG10004	232	1327	33.6
	150	HG10006	282	1991	39.5
	200	HG10008	332	2655	45.4
	250	HG10010	382	3318	51.7
	300	HG10012	432	3982	57.6
150 Tonne 1348 kN	50	HG15002	196	981	46.3
	100	HG15004	246	1963	55.3
	150	HG15006	296	2978	64.4
	200	HG15008	346	3926	73.5
	250	HG15010	396	4907	82.1
	300	HG15012	446	5889	91.6
200 Tonne 1815 kN	50	HG20002	216	1322	54.9
	150	HG20006	316	3989	91.2
	200	HG20008	366	5289	109.8
	300	HG20012	466	7977	146.1
300 Tonne* 3132 kN	50	HG30002	312	2281	184.2
	150	HG30006	412	6843	231.8
	300	HG30012	562	13685	303.0
400 Tonne* 3844 kN	50	HG40002	374	2800	269.9
	150	HG40006	474	8399	330.2
	300	HG40012	625	17077	420.9
500 Tonne* 5015 kN	50	HG50002	419	3653	401.0
	150	HG50006	519	10959	479.9
	300	HG50012	669	21919	599.2
600 Tonne* 5871 kN	50	HG60002	429	4277	474.0
	150	HG60006	529	12829	565.2
	250	HG60010	629	21383	655.6
	300	HG60012	679	25662	700.8
800 Tonne* 8075 kN	50	HG80002	474	5881	741.2
	150	HG80006	574	17649	868.2
	300	HG80012	724	35281	1057.8
1000 Tonne* 10062 kN	50	HG100002	564	7329	1061.9
	150	HG100006	664	21991	1212.9
	300	HG100012	814	43966	1438.8

*Available on request: no stock item



HG Series



Safety Practices

Good industry practice recommends not exceeding 80% of maximum rated capacities of all our products.

Optional Tilt-Saddles



Saddles tilt to a 5% maximum to adjust to the load. View our cylinder accessories page to figure out what saddle best fits these cylinders.

pg 45



Related Product: Gauges

Reduce the risk of overloading your product by using a gauge. A variety of graduations and types to suit any need.

pg 71



Safety Instructions

Visit our DO'S and DON'TS section to review the best methods of operation. Always be prepared.

pg 102

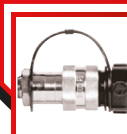

High-Flow Couplers

High-Flow Coupler: CH38F is included on all models (except where specified).

H

HD

HL

HF

HLN

HLNF

HG

HGD

HC

HDC

HU

HDU

HULN

HUC

HUCC

HT

HP

HPD

Cylinder accessories



High Tonnage Single Acting Cylinders

HG Series - Heavy Lifting, Load Return

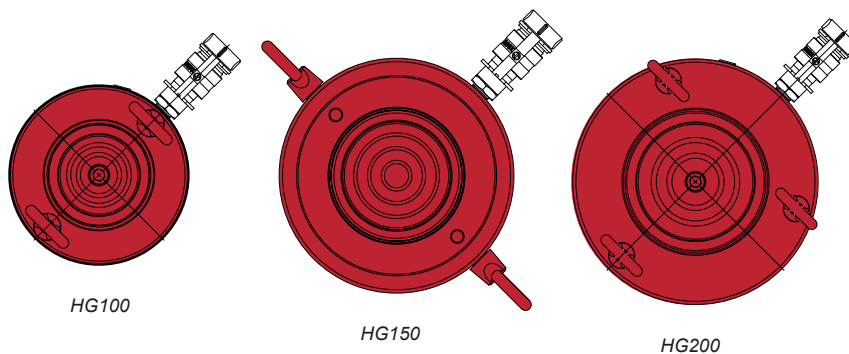
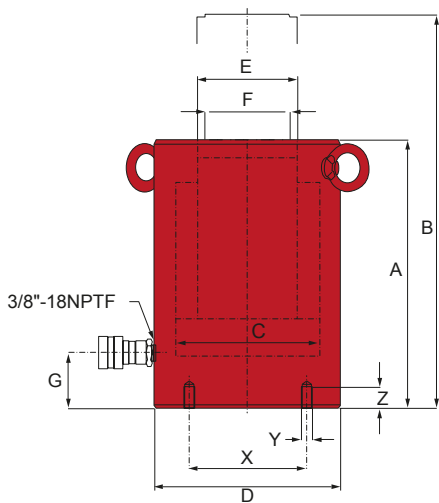

Optional Tilt-Saddles



Saddles tilt to a 5% maximum to adjust to the load. View our cylinder accessories page to figure out what saddle best fits these cylinders.

pg 45

High-Flow Couplers



High-Flow Coupler: CH38F is included on all models (except where specified).

Related Product: Gauges



Reduce the risk of overloading your product by using a gauge. A variety of graduations and types to suit any need.

pg 71

Safety Instructions



Visit our DO'S and DON'TS section to review the best methods of operation. Always be prepared.

pg 102

Cylinder Capacity	Stroke (mm)	Model Number	Cylinder Effective Area (cm ²)	Oil Capacity (cc)	Weight (kg)
95 Tonne 911 kN	50	HG10002	132.7	664	27.7
	100	HG10004	132.7	1327	33.6
	150	HG10006	132.7	1991	39.5
	200	HG10008	132.7	2655	45.4
	250	HG10010	132.7	3318	51.7
	300	HG10012	132.7	3982	57.6
150 Tonne 1348 kN	50	HG15002	196.3	981	46.3
	100	HG15004	196.3	1963	55.3
	150	HG15006	196.3	2978	64.4
	200	HG15008	196.3	3926	73.5
	250	HG15010	196.3	4907	82.1
	300	HG15012	196.3	5889	91.6
200 Tonne 1815 kN	50	HG20002	264.4	1322	54.9
	150	HG20006	264.4	3989	91.2
	200	HG20008	264.4	5289	109.8
	300	HG20012	264.4	7977	146.1
300 Tonne* 3132 kN	50	HG30002	456.2	2281	184.2
	150	HG30006	456.2	6843	231.8
	300	HG30012	456.2	13685	303.0
400 Tonne* 3844 kN	50	HG40002	559.9	2800	269.9
	150	HG40006	559.9	8399	330.2
	300	HG40012	559.9	17077	420.9
500 Tonne* 5015 kN	50	HG50002	730.6	3653	401.0
	150	HG50006	730.6	10959	479.9
	300	HG50012	730.6	21919	599.2
600 Tonne* 5871 kN	50	HG60002	855.3	4277	474.0
	150	HG60006	855.3	12829	565.2
	250	HG60010	855.3	21383	655.6
	300	HG60012	855.3	25662	700.8
800 Tonne* 8075 kN	50	HG80002	1176.3	5881	741.2
	150	HG80006	1176.3	17649	868.2
	300	HG80012	1176.3	35281	1057.8
1000 Tonne* 10062 kN	50	HG100002	1465.7	7329	1061.9
	150	HG100006	1465.7	21991	1212.9
	300	HG100012	1465.7	43966	1438.8

* Available on request: no stock item

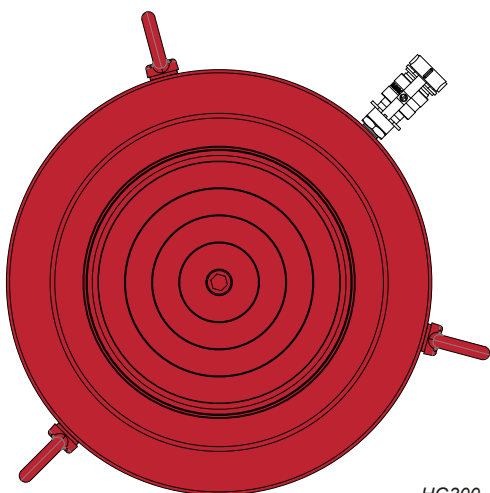

HG300 - HG1000



HG Series

Safety Practices
Good industry practice recommends not exceeding 80% of maximum rated capacities of all our products.

Model Number	Collapsed Height A (mm)	Extended Height B (mm)	Cylinder Bore Dia. C (mm)	Outside Dia. D (mm)	Plunger Dia. E (mm)	Saddle Dia. F (mm)	Base To Inlet Port G (mm)	Base Mounting Holes		
								Bolt Circle X (mm)	Thread Size Y	Thread Depth Z (mm)
HG10002	182	232	130	165	95	75	54	95	M12	22
HG10004	232	332	130	165	95	75	54	95	M12	22
HG10006	282	432	130	165	95	75	54	95	M12	22
HG10008	332	532	130	165	95	75	54	95	M12	22
HG10010	382	632	130	165	95	75	54	95	M12	22
HG10012	432	732	130	165	95	75	54	95	M12	22
HG15002	196	246	158	205	110	94	61	130	M12	22
HG15004	246	346	158	205	110	94	61	130	M12	22
HG15006	296	446	158	205	110	94	61	130	M12	22
HG15008	346	546	158	205	110	94	61	130	M12	22
HG15010	396	646	158	205	110	94	61	130	M12	22
HG15012	446	746	158	205	110	94	61	130	M12	22
HG20002	216	266	183	235	135	113	67	165	M12	20
HG20006	316	466	183	235	135	113	67	165	M12	20
HG20008	366	566	183	235	135	113	67	165	M12	20
HG20012	466	766	183	235	135	113	67	165	M12	20
HG30002	312	362	241	310	197	177	101	180	M16	36
HG30006	412	562	241	310	197	177	101	180	M16	36
HG30012	562	862	241	310	197	177	101	180	M16	36
HG40002	374	424	267	350	216	196	114	205	M16	36
HG40006	474	625	267	350	216	196	114	205	M16	36
HG40012	625	930	267	350	216	196	114	205	M16	36
HG50002	419	469	305	400	248	228	114	250	M24	38
HG50006	519	669	305	400	248	228	114	250	M24	38
HG50012	669	969	305	400	248	228	114	250	M24	38
HG60002	429	479	330	430	267	247	114	275	M24	38
HG60006	529	679	330	430	267	247	114	275	M24	38
HG60010	629	879	330	430	267	247	114	275	M24	38
HG60012	679	979	330	430	267	247	114	275	M24	38
HG80002	474	524	387	505	317	297	149	330	M24	38
HG80006	574	724	387	505	317	297	149	330	M24	38
HG80012	724	1024	387	505	317	297	149	330	M24	38
HG100002	564	614	432	560	343	323	174	375	M24	38
HG100006	664	814	432	560	343	323	174	375	M24	38
HG100012	814	1114	432	560	343	323	174	375	M24	38

- H
- HD
- HL
- HF
- HLN
- HLNF
- HG**
- HDG
- HC
- HDC
- HU
- HDU
- HULN
- HUC
- HUUC
- HT
- HP
- HPD
- Cylinder accessories



High Tonnage Double Acting Cylinders

HDG Series - Heavy Lifting



Capacity:

95 - 1000 Tonnes

Stroke:

50 - 300 mm

Max. Operating Pressure:

700 BAR

Min. - Max. Height:

182 - 1114 mm

Side load 10% @ max stroke

Flow Control Valves



Control the speed of your cylinder by adding a flow control valve.

pg 74

Related Product: Hoses



We offer a variety of hoses, fittings, lengths and materials.

pg 73

Safety Instructions



Visit our DO'S and DON'TS section to review the best methods of operation. Always be prepared.

pg 102

- Cylinders are burnish rolled creating a smoother finish than honing
- Industrial hard chrome plated plunger prevents scratching and corrosion
- Base mounting holes standard on all models
- Plunger wiper seals out dirt and contamination
- High strength steel construction from gun drilled solid bar
- High flow 3/8" NPTF couplers
- Maximum working pressure: 10,000 psi / 700 bar
- Custom sizes are available upon request

Gas/Diesel Engine Pumps

These HDG cylinders pair up well with a Gas or Diesel Engine pump. We offer a variety of different flow rates, motor sizes and reservoir sizes on our gas/diesel engine pumps. Contact your local BVA dealer for more details.



- Gas engine pump will provide 700 BAR hydraulic force at remote locations.
- Industrial grade 5.5 hp. (4.1 kN) Honda gas engine or 4.6 hp. (3.5 kN) HATZ diesel engine.
- Ideal for applications where electricity isn't easily accessible.
- Two speed pump designed for rapid cylinder advance.
- Gas pump features a sturdy protective roll cage for use in the toughest environments.
- Optional electric start with Diesel Engine.

Electric Motor Pumps

These HDG cylinders pair up well with Electric Motor pumps. We offer a variety of different flow rates and motor sizes on our electric motor pumps. Contact your local BVA dealer for more details.



- Meets OSHA regulations for sound (80dBA).
- Two speed pump designed for rapid cylinder advance.
- Internal filter screens contamination to prevent pump damage.
- All units are wired as 240 VAC 50 Hz; Optional wiring: 115VAC 50Hz.
- 100% Duty Cycle TEFC motors.
- All hand pendants are wired at 24VAC for safety.
- Full load starting capability.

Quick Reference Guide

Cylinder Capacity	Stroke (mm)	Model Number	Collapsed Height (mm)	Oil Capacity (cc)	Weight (kg)
95 Tonne 911/419 kN	50	HDG10002	182	664	27.7
	100	HDG10004	232	1327	33.6
	150	HDG10006	282	1991	39.5
	200	HDG10008	332	2655	45.4
	250	HDG10010	382	3318	51.7
	300	HDG10012	432	3982	57.6
150 Tonne 1348/695 kN	50	HDG15002	196	981	46.3
	100	HDG15004	246	1963	55.3
	150	HDG15006	296	2978	64.4
	200	HDG15008	346	3926	73.5
	250	HDG15010	396	4907	82.1
	300	HDG15012	446	5889	91.6
200 Tonne 1816/833 kN	50	HDG20002	216	1322	54.9
	150	HDG20006	316	3989	91.2
	200	HDG20008	366	5289	109.8
	300	HDG20012	466	7977	146.1
300 Tonne* 3132/1039 kN	50	HDG30002	312	2281	184.2
	150	HDG30006	412	6843	231.8
	300	HDG30012	562	13685	303.0
400 Tonne* 3844/1352 kN	50	HDG40002	374	2800	269.9
	150	HDG40006	474	8399	330.2
	305	HDG40012	625	17077	420.9
500 Tonne* 5016/1700 kN	50	HDG50002	419	3653	401.0
	150	HDG50006	519	10959	479.9
	300	HDG50012	669	21919	599.2
600 Tonne* 5871/2028 kN	50	HDG60002	429	4277	474.0
	150	HDG60006	529	12829	565.2
	250	HDG60010	629	21383	630.0
	300	HDG60012	679	25662	700.8
800 Tonne* 8073/2657 kN	50	HDG80002	474	5881	741.2
	150	HDG80006	574	17649	868.2
	300	HDG80012	724	35281	1057.8
1000 Tonne* 10057/3719 kN	50	HDG100002	564	7329	1061.9
	150	HDG100006	664	21991	1212.9
	300	HDG100012	814	43966	1438.8

* Available on request

See next pages (pg.34-35) to view more detailed stats on High Tonnage Double Acting Cylinders.



HDG Series



Safety Practices
Good industry practice recommends not exceeding 80% of maximum rated capacities of all our products.

Optional Tilt-Saddles



Saddles tilt to a 5% maximum to adjust to the load. View our cylinder accessories page to figure out what saddle best fits these cylinders.

pg 45

Related Product: Gauges



Reduce the risk of overloading your product by using a gauge. A variety of graduations and types to suit any need.

pg 71

High-Flow Couplers



High-Flow Coupler: CH38F is included on all models (except where specified).

Relief Valve



All double acting cylinders are equipped with a pressure relief valve located next to the retract port. These pressure relief valves help prevent cylinder overpressurization on the return port side of the cylinder.

- H
- HD
- HL
- HF
- HLN
- HLNF
- HG
- HDG**
- HC
- HDC
- HU
- HDU
- HULN
- HUC
- HUDC
- HT
- HP
- HPD
- Cylinder accessories



High Tonnage Double Acting Cylinders

HDG Series - Heavy Lifting

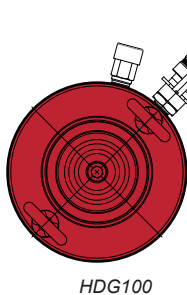
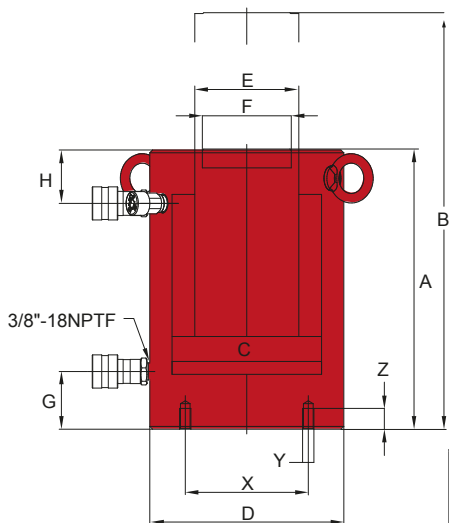

HDG100

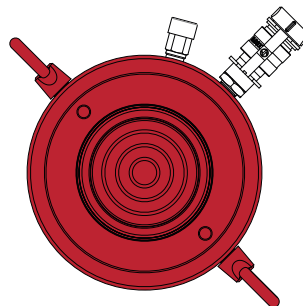

HDG150

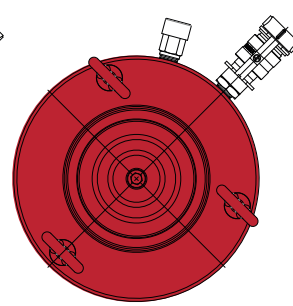

HDG200

Relief Valve

All double acting cylinders are equipped with a pressure relief valve located next to the retract port. These pressure relief valves help prevent cylinder over pressurization on the return port side of the cylinder.



Optional Tilt-Saddles

Saddles tilt to a 5% maximum to adjust to the load. View our cylinder accessories page to figure out what saddle best fits these cylinders.



pg 45

Safety Instructions

Visit our DO'S and DON'TS section to review the best methods of operation. Always be prepared.



pg 102

High-Flow Couplers

High-Flow Coupler: CH38F is included on all models (except where specified).



Cylinder Capacity	Stroke (mm)	Model Number	Maximum Cylinder Capacity (Tonne)		Cylinder Effective Area (cm ²)		Oil Capacity (cc)		Weight (kg)
			Push	Pull	Push	Pull	Push	Pull	
95 Tonne 911/419 kN	50	HDG10002	92.9	43.3	132.7	61.9	664	309	27.7
	100	HDG10004	92.9	43.3	132.7	61.9	1327	618	33.6
	150	HDG10006	92.9	43.3	132.7	61.9	1991	928	39.5
	200	HDG10008	92.9	43.3	132.7	61.9	2655	1237	45.4
	250	HDG10010	92.9	43.3	132.7	61.9	3318	1546	51.7
150 Tonne 1348/695 kN	300	HDG10012	92.9	43.3	132.7	61.9	3982	1856	57.6
	50	HDG15002	137.4	70.9	196.3	101.3	981	506	46.3
	100	HDG15004	137.4	70.9	196.3	101.3	1963	1013	55.3
	150	HDG15006	137.4	70.9	196.3	101.3	2978	1447	64.4
	200	HDG15008	137.4	70.9	196.3	101.3	3926	2025	73.5
200 Tonne 1816/833 kN	250	HDG15010	137.4	70.9	196.3	101.3	4907	2531	82.1
	300	HDG15012	137.4	70.9	196.3	101.3	5889	3038	91.6
	50	HDG20002	185.2	84.9	264.5	121.3	1322	606	54.9
	150	HDG20006	185.2	84.9	264.5	121.3	3989	1905	91.2
	200	HDG20008	185.2	84.9	264.5	121.3	5289	2426	109.8
300 Tonne* 3132/1039 kN	300	HDG20012	185.2	84.9	264.5	121.3	7977	3809	146.1
	50	HDG30002	319.3	106.0	456.2	151.4	2281	757	184.2
	150	HDG30006	319.3	106.0	456.2	151.4	6843	2270	231.8
400 Tonne* 3844/1352 kN	300	HDG30012	319.3	106.0	456.2	151.4	13685	4541	303.0
	50	HDG40002	391.9	137.8	559.9	196.9	2800	967	269.9
	150	HDG40006	391.9	137.8	559.9	196.9	8399	2902	330.2
500 Tonne* 5016/1700 kN	300	HDG40012	391.9	137.8	559.9	196.9	17077	6004	420.9
	50	HDG50002	511.5	173.4	730.7	247.7	3653	1238	401.0
	150	HDG50006	511.5	173.4	730.7	247.7	10959	3713	479.9
600 Tonne* 5871/2028 kN	300	HDG50012	511.5	173.4	730.7	247.6	21919	7427	599.2
	50	HDG60002	598.7	206.8	855.3	295.4	4277	1477	474.0
	150	HDG60006	598.7	206.8	855.3	295.4	12829	4431	565.2
800 Tonne* 8073/2657 kN	250	HDG60010	598.7	206.8	855.3	295.4	19422	6643	630.0
	300	HDG60012	598.7	206.8	855.3	295.4	25662	8862	700.8
	50	HDG80002	823.2	271.0	1176	387.1	5881	1935	741.2
1000 Tonne* 10062/3719 kN	150	HDG80006	823.2	271.0	1176	387.1	17649	5806	868.2
	300	HDG80012	823.2	271.0	1176	387.1	35281	11611	1057.8
	50	HDG100002	1025.0	379.3	1465	541.8	7329	2709	1061.9
1000 Tonne* 10062/3719 kN	150	HDG100006	1025.0	379.3	1465	541.8	21991	8126	1212.9
	300	HDG100012	1025.0	379.3	1465	541.8	43966	16252	1438.8

* Available on request: no stock item

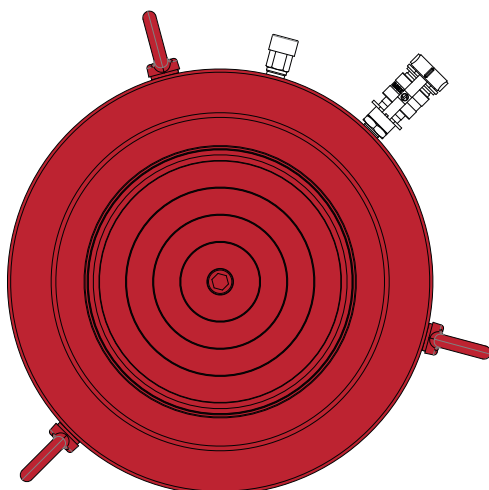

HDG300 - HDG1000



HDG Series

80%

Safety Practices

Good industry practice recommends not exceeding 80% of maximum rated capacities of all our products.

Model Number	Collapsed Height A (mm)	Extended Height B (mm)	Cylinder Bore Dia. C (mm)	Outside Dia. D (mm)	Plunger Dia. E (mm)	Saddle Dia. F (mm)	Base To Inlet Port G (mm)	Top To Retract Port H (mm)	Base Mounting Holes		
									Bolt Circle X (mm)	Thread Size	Thread Depth Z (mm)
HDG10002	182	232	130	165	95	75	54	48	95	M12	22
HDG10004	232	332	130	165	95	75	54	48	95	M12	22
HDG10006	282	432	130	165	95	75	54	48	95	M12	22
HDG10008	332	532	130	165	95	75	54	48	95	M12	22
HDG10010	382	632	130	165	95	75	54	48	95	M12	22
HDG10012	432	732	130	165	95	75	54	48	95	M12	22
HDG15002	196	246	158	205	110	94	61	56	130	M12	22
HDG15004	246	346	158	205	110	94	61	56	130	M12	22
HDG15006	296	446	158	205	110	94	61	56	130	M12	22
HDG15008	346	546	158	205	110	94	61	56	130	M12	22
HDG15010	396	646	158	205	110	94	61	56	130	M12	22
HDG15012	446	746	158	205	110	94	61	56	130	M12	22
HDG20002	216	266	183	235	135	113	67	56	165	M12	20
HDG20006	316	466	183	235	135	113	67	56	165	M12	20
HDG20008	366	566	183	235	135	113	67	56	165	M12	20
HDG20012	466	766	183	235	135	113	67	56	165	M12	20
HDG30002	312	362	241	310	197	177	101	75	180	M16	36
HDG30006	412	562	241	310	197	177	101	75	180	M16	36
HDG30012	562	862	241	310	197	177	101	75	180	M16	36
HDG40002	374	424	267	350	216	196	114	105	205	M16	36
HDG40006	474	625	267	350	216	196	114	105	205	M16	36
HDG40012	625	925	267	350	216	196	114	105	205	M16	36
HDG50002	419	469	305	400	248	228	114	135	250	M24	38
HDG50006	519	669	305	400	248	228	114	135	250	M24	38
HDG50012	669	969	305	400	248	228	114	135	250	M24	38
HDG60002	429	479	330	430	267	247	114	135	275	M24	38
HDG60006	529	679	330	430	267	247	114	135	275	M24	38
HDG60010	629	879	330	430	267	247	114	135	275	M24	38
HDG60012	679	979	330	430	267	247	114	135	275	M24	38
HDG80002	474	524	387	505	317	297	149	135	330	M24	38
HDG80006	574	724	387	505	317	297	149	135	330	M24	38
HDG80012	724	1024	387	505	317	297	149	135	330	M24	38
HDG100002	564	614	432	560	343	323	174	170	375	M24	38
HDG100006	664	814	432	560	343	323	174	170	375	M24	38
HDG100012	814	1114	432	560	343	323	174	170	375	M24	38

- H
- HD
- HL
- HF
- HLN
- HLNF
- HG
- HDG**
- HC
- HDC
- HU
- HDU
- HULN
- HUC
- HUCD
- HT
- HP
- HPD
- Cylinder accessories



Hollow Plunger Cylinders

HC Series

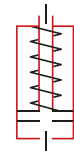

Capacity:

12-100 Tonnes

Stroke:

8 - 155 mm

Max. Operating Pressure:

700 BAR

Min. - Max. Height:

60 - 486 mm

Here is a HC6006T in a pulling application.



HC3002T

- Ideal for pulling and pushing applications.
- Heavy duty compression spring.
- Dual wipers help prevent contamination.
- Collar thread protector.
- High flow coupler with dust cap.
- XT cylinders do not have internal plunger threads.
- 60 and 100 Tonne models are equipped with carrying handles.

Cylinder Capacity	Stroke (mm)	Model Number	Cylinder Effective Area (cm ²)	Oil Capacity (cc)	Weight (kg)	Collapsed Height A (mm)	Extended Height B (mm)	Bore Dia. C (mm)	O.D. D (mm)
12 Tonne 129 kN	8	HC1201T	18.8	15	1.5	60	68	49	70
	41	HC1202	18.8	77	2.6	121	162	49	70
	41	HC1202XT	18.8	77	2.6	121	162	49	70
	76	HC1203XT	18.8	143	3.9	184	260	49	70
20 Tonne 217 kN	51	HC2002T	31.6	161	7.2	162	213	64	100
	154	HC2006T	31.6	487	13.4	306	460	64	100
30 Tonne 280 kN	64	HC3002T	40.8	261	10.4	179	243	72	114
	155	HC3006T	40.8	634	19.5	331	486	72	114
60 Tonne 578 kN	76	HC6003T*	84.2	641	29.8	248	324	104	159
	152	HC6006T*	84.2	1282	36.8	324	477	104	159
100 Tonne 980 kN	76	HC10003T*	142.8	1087	51.4	254	330	135	213

* Cylinder is fitted with carrying handles.

Optional threaded hollow saddles				
Cylinder Model Number	Saddle Model Nr.	Saddle Dimensions (mm)		
		A	B	C
HC20XXT	APS20	55	1" - 8UNC	10
HC30XXT	APS30	63	1¼" - 7UNC	10
HC60XXT	APS60	92	1½" - 5,5UNC	13

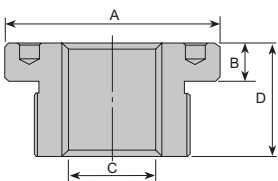

All HC-cylinders are standard equipped with smooth hollow saddles (except the HC1201T and HC1202)



HC Series

Safety Practices

Good industry practice recommends not exceeding 80% of maximum rated capacities of all our products.

Combo Kits
Most cylinders are available in easy to order kits: cylinder, gauge, couplers, hose and pump.

64 pg

Related Product: Gauges
Reduce the risk of overloading your product by using a gauge. A variety of graduations and types to suit any need.

71 pg

Safety Instructions
Visit our DO'S and DON'TS section to review the best methods of operation. Always be prepared.

102 pg

High-Flow Couplers
High-Flow Coupler: CH38F is included on all models (except where specified).

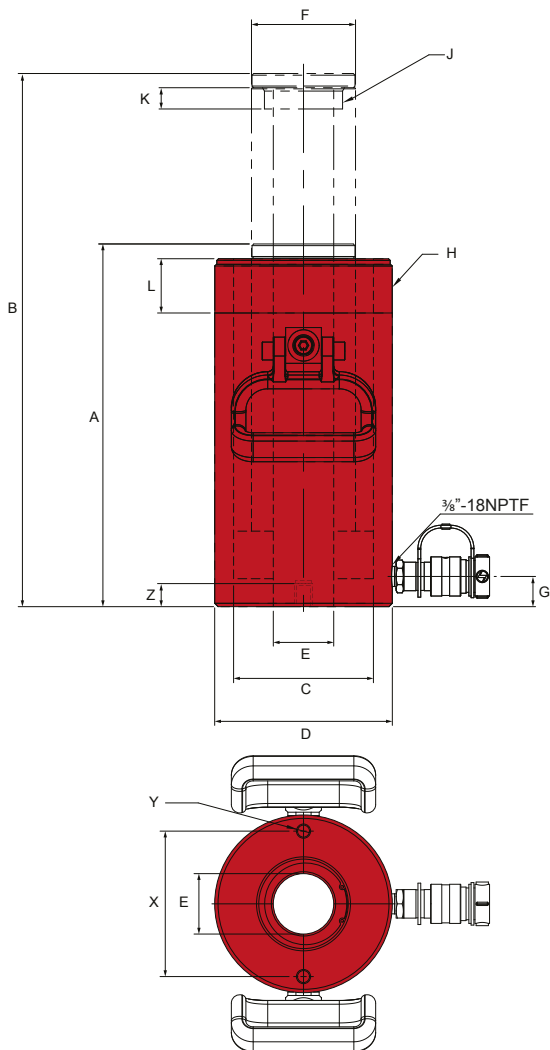

Model Number	Plunger				Collar Thread		Base to Inlet Port G (mm)	Base Mounting Hole		
	I.D. E (mm)	O.D. F (mm)	Internal Thread J	Internal Thread Length K (mm)	Diameter H	Length L (mm)		Bolt Circle X (mm)	Thread Y	Thread Depth Z (mm)
HC1201T	19	35	¼"-16UN	16	2¾"-16N	46	14	51	⅝"-18UNC	9
HC1202	19	35	¼"-16UN	16	2¾"-16N	46	15	51	⅝"-18UNC	9
HC1202XT	19	35	-	-	2¾"-16N	46	15	51	⅝"-18UNC	9
HC1203XT	19	35	-	-	2¾"-16N	46	19	51	⅝"-18UNC	9
HC2002T	27	55	1-⅞"-16UN	19	3⅞"-12N	38	19	83	⅜"-16UNC	9
HC2006T	27	55	1-⅞"-16UN	19	3⅞"-12N	38	19	83	⅜"-16UNC	9
HC3002T	33	63	1-⅞"-16UN	22	4½"-12N	42	23	92	⅜"-16UNC	14
HC3006T	33	63	1-⅞"-16UN	22	4½"-12N	42	23	92	⅜"-16UNC	14
HC6003T*	54	93	2¾"-16UN	19	6¼"-12N	49	27	130	½"-13UNC	14
HC6006T*	54	93	2¾"-16UN	19	6¼"-12N	49	27	130	½"-13UNC	14
HC10003T*	79	125	4"-16UN	25	8⅝"-12N	60	27	178	⅝"-11UNC	19

* Cylinder is fitted with carrying handles

H
HD
HL
HF
HLN
HLNF
HG
HDG
HC
HDC
HU
HDU
HULN
HUC
HUCD
HT
HP
HPD
Cylinder accessories

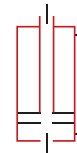

Double Acting Hollow Plunger Cylinders

HDC Series



HDC3010

HDC6006



HDC10001

Capacity:

30 - 150 Tonnes

Stroke:

38 - 257 mm

Max. Operating Pressure:

700 BAR

Min. - Max. Height:

165 - 718 mm

Related Product: Gauges
 Reduce the risk of overloading your product by using a gauge. A variety of graduations and types to suit any need. pg 71



Combo Kits
 Most cylinders are available in easy to order kits: Cylinder, Gauge, Couplers, Hose and Pump. pg 64



Related Product: Hoses
 We offer a variety of hoses, fittings, lengths and materials. pg 73



- Ideal for pushing and pulling applications.
- Dual wipers help prevent contamination.
- CH38F - 3/8" high flow female coupler.
- Hard chrome coated plunger prevents rust and corrosion.
- Hardened steel seat.

Cylinder Capacity		Stroke (mm)	Model Number	Oil Capacity		Cylinder Effective area		Col-lapsed Height (mm)	Extended Height (mm)	Center Hole I.D. (mm)	Plunger O.D. (mm)	Weight (kg)
Push	Pull			Push (cc)	Pull (cc)	Push (cm ²)	Pull (cm ²)					
30 Tonne 280 kN	18 Tonne 176 kN	178	HDC3007	492	328	40,84	25,57	331	509	33	63	19.5
		257	HDC3010	1051	658	40,84	25,57	432	689	33	63	25.7
60 Tonne 578 kN	40 Tonne 385 kN	89	HDC6003*	750	500	84,23	56,14	248	337	54	92	29.8
		165	HDC6006*	1390	926	84,23	56,14	324	489	54	92	36.8
		257	HDC6010*	2165	1443	84,23	56,14	438	695	54	92	51.0
100 Tonne 981 kN	64 Tonne 625 kN	38	HDC10001	545	347	142,94	91,11	165	203	79	125	33.4
		76	HDC10003*	1089	694	142,94	91,11	254	330	79	125	51.4
		152	HDC10006*	2169	1388	142,94	91,11	343	495	79	125	69.5
		257	HDC10010*	3679	2345	142,94	91,11	461	718	79	125	90.2
145 Tonne 1407 kN	75 Tonne 733 kN	203	HDC15008*	4247	2170	204,99	106,81	349	552	79	150	108.5

* Are equipped with carrying handles.

Optional threaded hollow saddles				
Cylinder Model Number	Saddle Model Nr.	Saddle Dimensions (mm)		
		A	B	C
HC20XXT	APS20	55	1" - 8UNC	10
HC30XXT	APS30	63	1 1/4" - 7UNC	10
HC60XXT	APS60	92	1 5/8" - 5,5UNC	13

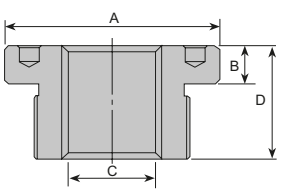

All HC-cylinders are standard equipped with smooth hollow saddles (except the HC1201T and HC1202)

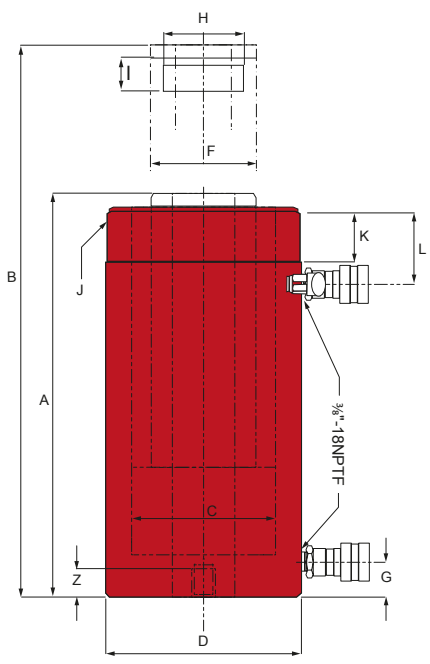
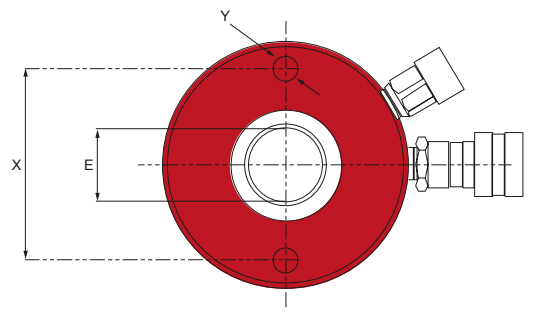

HDC Series

80% Safety Practices
 Good industry practice recommends not exceeding 80% of maximum rated capacities of all our products.

Relief Valve
 All double acting cylinders are equipped with a pressure relief valve located next to the retract port. These pressure relief valves help prevent cylinder over pressurization on the return port side of the cylinder.

High-Flow Couplers
 High-Flow Coupler: CH38F is included on all models (except where specified).

Safety Instructions
 Visit our DO'S and DON'TS section to review the best methods of operation. Always be prepared.

Model Number	Min. Height A (mm)	Max. Height B (mm)	Dia. of Center Tube C (mm)	O.D. D (mm)	I.D. E (mm)	O.D. F (mm)	Base to Inlet Port G (mm)	Top to Return Port L (mm)	Internal Thread H	Internal Thread Length I (mm)	Collar Thread		Base Mounting Hole		
											Dia. J	Length K (mm)	Bolt Circle X (mm)	Thread Y	Thread Depth Z (mm)
HDC3007	331	509	85	114	33	63	23	60	1 1/4"-16UN	24	4 1/2"-12N	42	92	3/8"-16UNC	14
HDC3010	432	689	85	114	33	63	23	60	1 1/4"-16UN	24	4 1/2"-12N	42	92	3/8"-16UNC	14
HDC6003*	248	337	125	159	54	92	27	67	2 3/4"-16UN	21	6 1/4"-12N	49	130	1/2" 13UNC	14
HDC6006*	324	489	125	159	54	92	27	67	2 3/4"-16UN	21	6 1/4"-12N	49	130	1/2" 13UNC	14
HDC6010*	438	695	125	159	54	92	27	67	2 3/4"-16UN	21	6 1/4"-12N	49	130	1/2" 13UNC	14
HDC10001	165	203	165	213	79	125	27	44	4"- 16UN	27	-	-	178	5/8" 11UNC	19
HDC10003*	254	330	165	213	79	125	27	86	4"- 16UN	27	8 3/8"-12N	60	178	5/8" 11UNC	19
HDC10006*	343	495	165	213	79	125	27	86	4"- 16UN	27	8 3/8"-12N	60	178	5/8" 11UNC	19
HDC10010*	461	718	165	213	79	125	27	86	4"- 16UN	27	8 3/8"-12N	60	178	5/8" 11UNC	19
HDC15008*	349	552	190	248	79	150	38	60	4 1/4"- 12N	35	-	-	-	-	-

* Are equipped with carrying handles.

H
 HD
 HL
 HF
 HLN
 HLNf
 HG
 HDG
 HC
HDC
 HU
 HDU
 HULN
 HUC
 HUDC
 HT
 HP
 HPD
 Cylinder accessories



Aluminum Single Acting Cylinders

HU Series - General Purpose, Spring Return, Lightweight

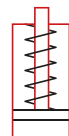

HU10006T



HU5506T



HU2006T

Capacity:

20 - 95 Tonnes

Stroke:

50 - 254 mm

Max. Operating Pressure:

700 BAR

Min. - Max. Height:

174 - 636 mm

- Lightweight aluminum alloy construction.
- Up to 60% lighter than comparable tonnage steel cylinders.
- Convenient carry handle on 50 and 95 Tonne models.
- Hard anodized aluminum plunger provides extra protection against corrosion and wear.
- Integral steel protective plate.
- Maximum working pressure: 10,000 psi / 700 bar.

Aluminum vs. Steel Cylinders

Aluminum cylinders provide a great alternative to the traditional steel cylinder in many applications. Being up to 60% lighter in weight, Aluminum cylinders are easier portable and reduce user fatigue and strain. However, due to the finite properties of Aluminum vs. Steel, these cylinders should NOT be used in high cycle applications. The BVA Aluminum cylinders are designed for a maximum safety rating of 5,000 cycles. Under normal lifting applications this should provide a long service life.



HU5506T

Aluminum Cylinders

- 60% lighter in weight than steel.
- Easier portable and reduces user fatigue.
- Not to be used for high cycle applications.
- Under normal conditions, the maximum rated safety cycle life is 5,000 cycles.
- Base of the cylinder contains a steel plate*.



H5506

Steel Cylinders

- Much heavier than aluminum cylinders.
- Low portability on heavier cylinders which creates user fatigue and strain.
- Will out-perform aluminum cylinders in higher cycle applications.
- Can exceed aluminum cylinders maximum safety cycle life of 5,000 cycles.

*The base of the cylinders contain a steel plate with mounting holes that are designed to protect the cylinder from damage and should NOT be used in fixturing applications and ONLY be used to attach larger base mounting plates for lifting stability. They are NOT designed to withstand the full ratings of the cylinders.



Safety Practices

Good industry practice recommends not exceeding 80% of maximum rated capacities of all our products.



High-Flow Couplers

High-Flow Coupler: CH38F is included on all models (except where specified).

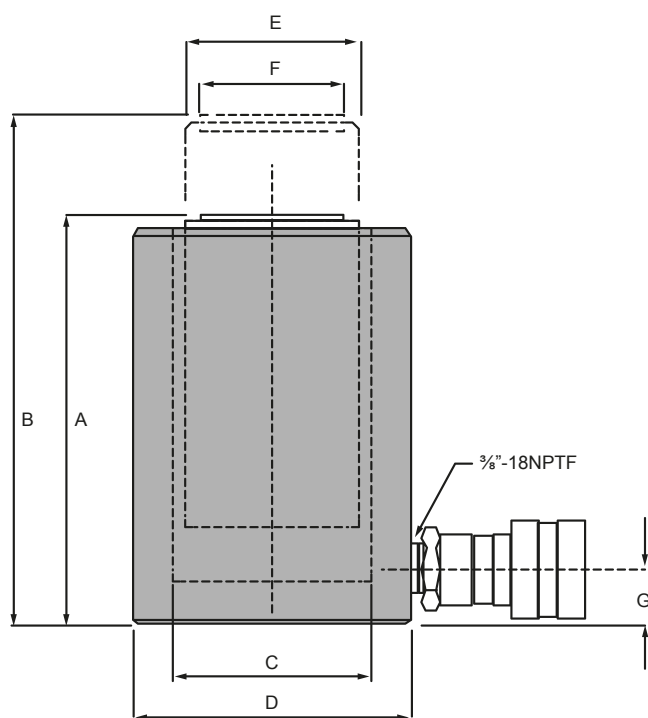

HU Series

Related Product: Gauges
 Reduce the risk of overloading your product by using a gauge. A variety of graduations and types to suit any need. pg 71

Related Product: Hoses
 We offer a variety of hoses, fittings, lengths and materials. pg 73

Safety Instructions
 Visit our DO'S and DON'TS section to review the best methods of operation. Always be prepared. pg 102

Cylinder Capacity	Stroke (mm)	Model Number	Cylinder Effective Area (cm ²)	Oil Capacity (cc)	Collapsed Height A (mm)	Extended Height B (mm)	Cylinder Bore Dia. C (mm)	Outside Dia. D (mm)	Plunger Dia. E (mm)	Saddle Dia. F (mm)	Base to Inlet Port G (mm)	Weight (kg)
20 Tonne 214 kN	50	HU2002T	31.2	156	174	224	63	85	51	40	27	3.0
	100	HU2004T	31.2	312	224	324	63	85	51	40	27	3.7
	150	HU2006T	31.2	468	274	424	63	85	51	40	27	4.4
30 Tonne 303 kN	50	HU3002T	44.2	221	181	231	75	100	60	40	34	4.7
	100	HU3004T	44.2	442	231	331	75	100	60	40	34	5.4
	150	HU3006T	44.2	663	281	431	75	100	60	40	34	6.1
50 Tonne 487 kN	50	HU5502T*	70.9	354	186	236	95	130	80	70	30	7.6
	100	HU5504T*	70.9	709	236	336	95	130	80	70	30	10.3
	150	HU5506T*	70.9	1063	286	436	95	130	80	70	30	11.6
	200	HU5508T*	70.9	1418	336	536	95	130	80	70	30	12.3
	250	HU5510T*	70.9	1772	386	636	95	130	80	70	30	14.2
95 Tonne 911 kN	51	HU10002T*	132.7	665	221	271	130	180	110	70	46	16.3
	102	HU10004T*	132.7	1328	271	371	130	180	110	70	46	19.5
	152	HU10006T*	132.7	1992	321	471	130	180	110	70	46	23.1
	202	HU10008T*	132.7	2655	371	571	130	180	110	70	46	30.8

* Are equipped with carrying handles.

H
 HD
 HL
 HF
 HLN
 HLNf
 HG
 HDG
 HC
 HDC
HU
 HDU
 HULN
 HUC
 HUDC
 HT
 HP
 HPD
 Cylinder accessories



Aluminum Double Acting Cylinders

HDU Series - General Purpose, Lightweight



- Lightweight aluminum alloy construction.
- Up to 60% lighter than comparable tonnage steel cylinders.
- Convenient carry handle.
- Hard anodized aluminum plunger provides extra protection against corrosion and wear.
- Steel protective plate on cylinder base.
- Maximum working pressure: 700 bar.

Capacity:

20 - 30 Tonnes

Stroke:

50 - 150 mm

Max. Operating Pressure:

700 BAR

Min. - Max. Height:

189 - 451 mm



HDU2006



HDU3006

Cylinder Capacity	Stroke (mm)	Model Number	Maximum Cylinder Capacity (Tonne)		Cylinder Effective Area (cm ²)		Oil Capacity (cc)		Weight (kg)
			Push	Pull	Push	Pull	Push	Pull	
20 Tonne 214/128 kN	50	HDU2002	20	13	31.17	18.61	156	93	5.7
	100	HDU2004	20	13	31.17	18.61	312	186	6.9
	150	HDU2006	20	13	31.17	18.61	468	279	8.0
30 Tonne 303/168 kN	50	HDU3002	30	17	44.18	24.54	221	123	7.6
	100	HDU3004	30	17	44.18	24.54	442	240	9.0
	150	HDU3006	30	17	44.18	24.54	663	368	10.4

NOTE: The base of the cylinders contain a Steel plate with mounting holes and is designed to protect the cylinder from damage and should NOT be used in fixturing applications and ONLY be used to attach a larger base mounting plate for lifting stability. They are NOT designed to withstand the full rating of the cylinder.



HDU Series

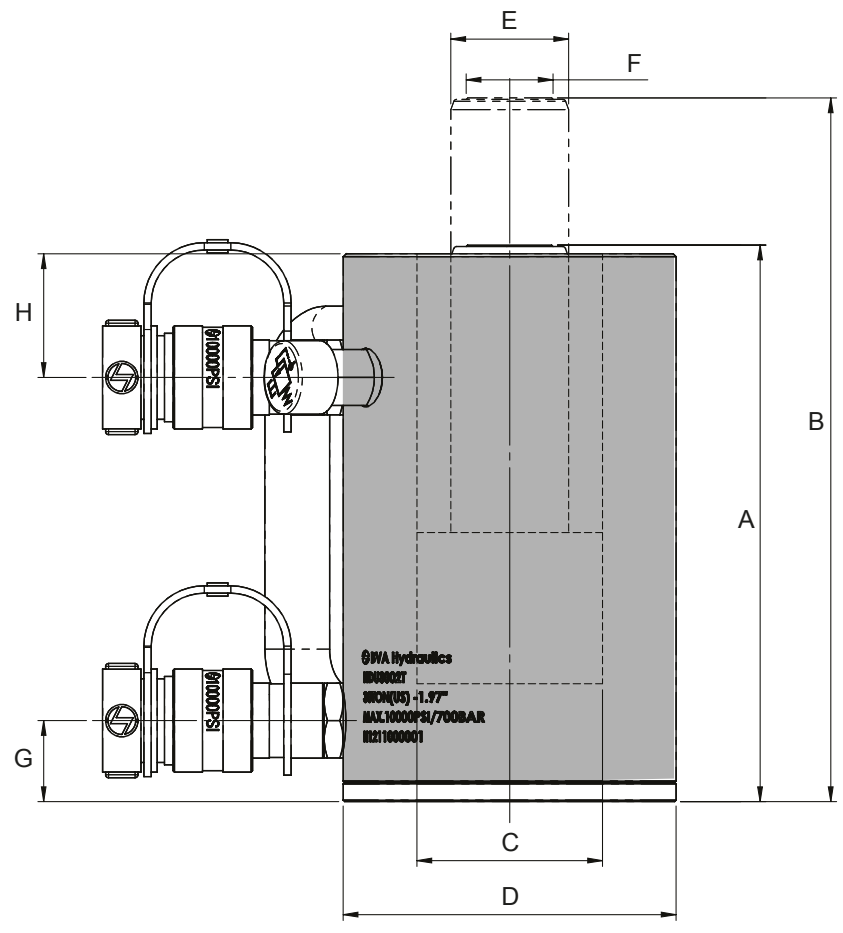

Related Product: Gauges
 Reduce the risk of overloading your product by using a gauge. A variety of graduations and types to suit any need. 71 pg

Safety Instructions
 Visit our DO'S and DON'TS section to review the best methods of operation. Always be prepared. 102 pg

Safety Practices
 Good industry practice recommends not exceeding 80% of maximum rated capacities of all our products.

High-Flow Couplers
 High-Flow Coupler: CH38F is included on all models (except where specified).

Relief Valve
 All double acting cylinders are equipped with a pressure relief valve located next to the retract port. These pressure relief valves help prevent cylinder over pressurization on the return port side of the cylinder.

Model Number	Collapsed Height A (mm)	Extended Height B (mm)	Cylinder Bore Dia. C (mm)	Outside Dia. D (mm)	Plunger Dia. E (mm)	Saddle Dia. F (mm)	Base To Inlet Port G (mm)	Top To Retract Port H (mm)
HDU2002	189	239	63	113	40	30	28	42
HDU2004	239	339	63	113	40	30	28	42
HDU2006	289	439	63	113	40	30	28	42
HDU3002	201	251	75	125	50	40	34	43
HDU3004	251	351	75	125	50	40	34	43
HDU3006	301	451	75	125	50	40	34	43

NOTE: The base of the aluminum cylinders contain a Steel plate with mounting holes and is designed to protect the cylinder from damage and should NOT be used in fixturing applications and ONLY be used to attach larger base mounting plates for lifting stability. The threads are NOT designed to withstand the full rating of the cylinder.

H
 HD
 HL
 HF
 HLN
 HLNf
 HG
 HDG
 HC
 HDC
 HU
HDU
 HULN
 HUC
 HUDC
 HT
 HP
 HPD
 Cylinder accessories



Lock Nut Aluminum Cylinders

HULN Series - Heavy Lifting w/ Mechanical Lock Nut

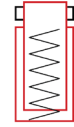

- Single acting cylinder with mechanical safety lock nut
- Designed to support loads without hydraulic pressure
- Overflow port prevents cylinders from over travel
- Spring return
- Lightweight aluminum cylinder body
- Steel saddle
- Hard anodized rod to resist corrosion and rust
- Maximum working pressure: 10,000 psi / 700 bar

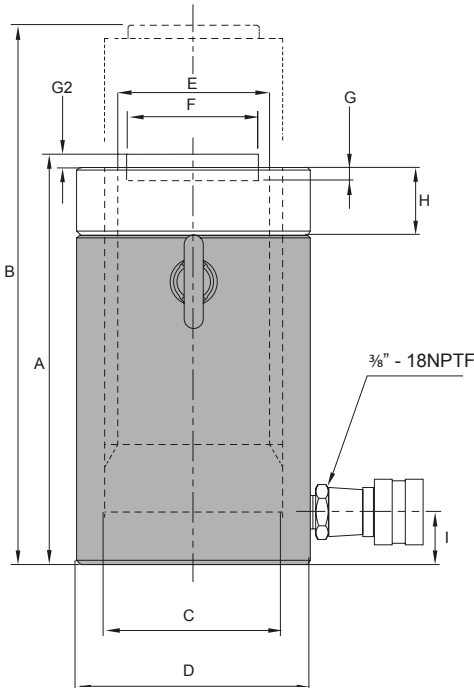

Safety Practices
Good industry practice recommends not exceeding 80% of maximum rated capacities of all our products.

Cylinder Capacity	Model Number	Stroke (mm)	Cylinder Effective Area (cm ²)	Oil Capacity (cc)	Collapsed height A (mm)	Extended Height B (mm)	C (mm)	D (mm)	E (mm)	F (mm)	G (mm)	H (mm)	I (mm)	Weight (kg)
30 Tonne 228 kN	HULN3002	50	41.9	213	196	247	73	114	64	51	3	32	38	6.8
	HULN3004	101	41.9	426	247	349	73	114	64	51	3	32	38	8.1
	HULN3006	152	41.9	639	298	450	73	114	64	51	3	32	38	9.5
	HULN3008	203	41.9	852	349	552	73	114	64	51	3	32	38	11.3
	HULN3010	254	41.9	1065	400	654	73	114	64	51	3	32	38	13.6
50 Tonne 489 kN	HULN5002	50	71.2	355	206	256	95	140	79	64	3	38	38	9.5
	HULN5004	101	71.2	710	257	358	95	140	79	64	3	38	38	11.7
	HULN5006	152	71.2	1064	307	460	95	140	79	64	3	38	38	13.6
	HULN5008	203	71.2	1418	358	562	95	140	79	64	3	38	38	15.8
	HULN5010	254	71.2	1773	409	664	95	140	79	64	3	38	38	18.12
100 Tonne 916 kN	HULN10002	50	133.4	664	212	263	130	203	108	89	3	44	38	20.4
	HULN10004	101	133.4	1327	263	365	130	203	108	89	3	44	38	23.5
	HULN10006	152	133.4	1991	301	453	130	203	108	89	3	44	38	27.2
	HULN10008	203	133.4	2655	365	568	130	203	108	89	3	44	38	31.7
	HULN10010	254	133.4	3318	415	670	130	203	108	89	3	44	38	36.2
150 Tonne 1359 kN	HULN15002	50	197.9	993	238	288	159	254	127	114	3	44	38	29.9
	HULN15004	101	197.9	1986	288	390	159	254	127	114	3	44	38	36.2
	HULN15006	152	197.9	2979	339	492	159	254	127	114	3	44	38	43.0
	HULN15008	203	197.9	3972	390	594	159	254	127	114	3	44	38	48.0
	HULN15010	254	197.9	4965	441	695	159	254	127	114	3	44	38	56.6

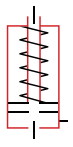

Single Acting Hollow Hole Aluminum Cylinders

HUC Series - Lightweight, Spring Return

- Light weight for easy handling.
- Ideal for pulling and pushing applications.
- Heavy duty compression spring.
- Dual wipers help prevent contamination.
- Collar thread protector.
- High flow coupler with dust cap.
- Equipped with carrying handles.

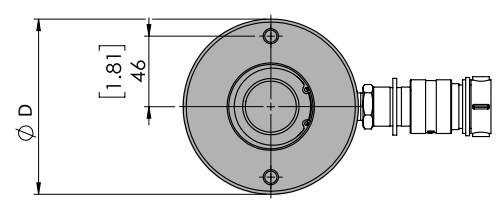
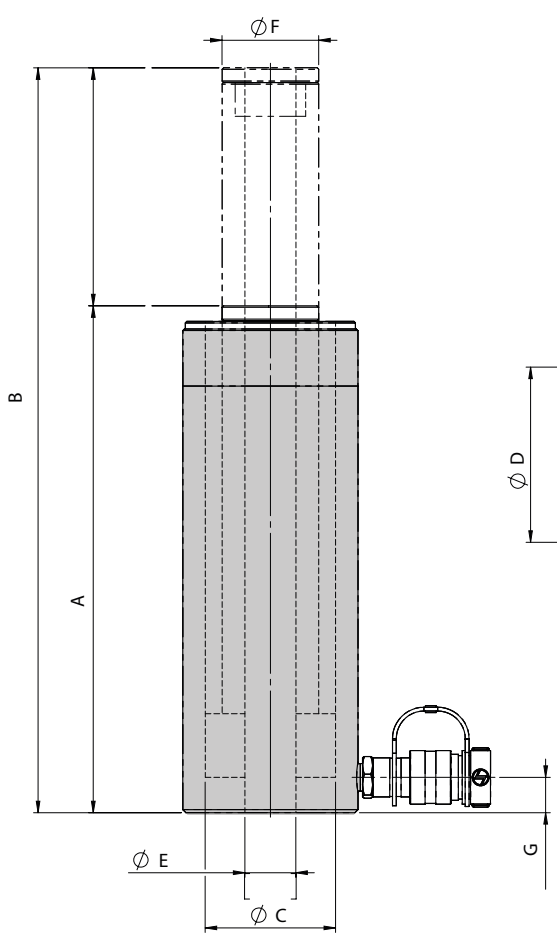

80%

Safety Practices
Good industry practice recommends not exceeding 80% of maximum rated capacities of all our products.

Related Product: Gauges
Reduce the risk of overloading your product by using a gauge. A variety of graduations and types to suit any need. pg 71

Cylinder Capacity	Model Number	Stroke (mm)	Effective Area (cm ²)	Oil Capacity (cm ³)	Collapsed Height A (mm)	Extended Height B (mm)	Bore Diameter C (mm)	Outer Diameter D (mm)	Cylinder hole E (mm)	Punger diameter F (mm)	Base to inlet port G (mm)	Weight (kg)
30 Tonne	HUC3003T	75	46.5	360.5	220	295	98	139	32.3	55	254	9.9
30 Tonne	HUC3006T	152	46.5	721.0	296	448	98	139	32.3	55	254	13.6
60 Tonne	HUC6003T	75	79.3	606.3	260	335	133	190	54	76	254	19.0
60 Tonne	HUC6006T	152	79.3	1212.6	336	488	133	190	54	76	254	24.9

- H
- HD
- HL
- HF
- HLN
- HLNF
- HG
- HDG
- HC
- HDC
- HU
- HDU
- HULN
- HUC
- HUDD
- HT
- HP
- HPD
- Cylinder accessories



Double Acting Aluminum Hollow Hole Cylinders

HUDC Series - Lightweight

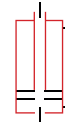

- Lightweight for easy handling.
- Ideal for pushing and pulling applications.
- Dual wipers help prevent contamination.
- CH38F - 3/8" high flow female coupler.
- Hard chrome coated plunger prevents rust and corrosion.
- Hardened steel seat.

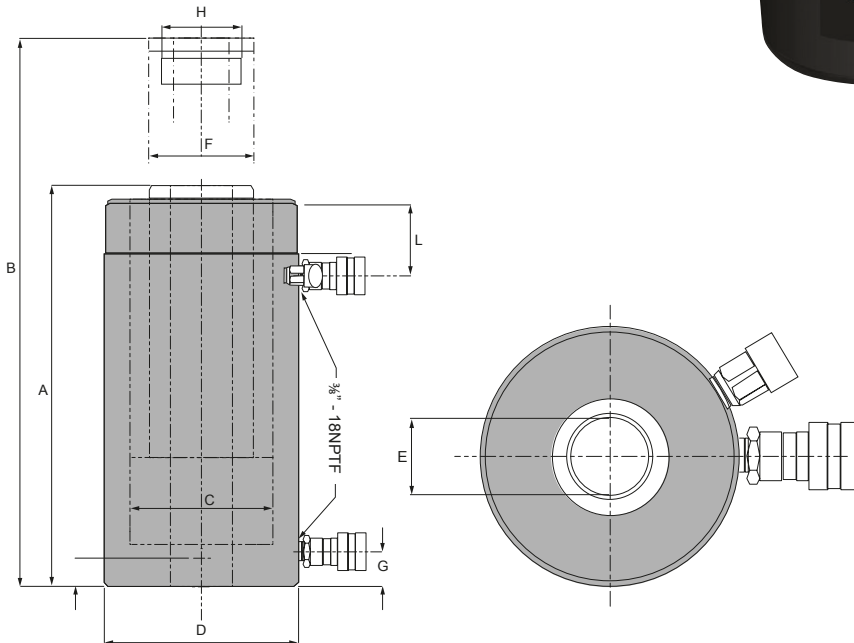

Safety Instructions
 Visit our DO'S and DON'TS section to review the best methods of operation. Always be prepared. 102 pg

Relief Valve
 All double acting cylinders are equipped with a pressure relief valve located next to the retract port. These pressure relief valves help prevent cylinder over pressurization on the return port side of the cylinder.

Cylinder Capacity	Model Number	Stroke (mm)	Effective Area (cm ²)		Oil Capacity (cm ³)		Collapsed Height A (mm)	Extended Height B (mm)	C (mm)	D (mm)	E (mm)	F (mm)	G (mm)	L (mm)	Weight (kg)
			Push	Pull	Push	Pull									
30 Tonne	HUDC3002	50	40.97	13.03	208	67	180	230	72,2	139,7	38	59,7	51	51	9,1
	HUDC3004	101	40.97	13.03	416	133	231	332	72,2	139,7	38	59,7	51	51	11,3
	HUDC3006	152	40.97	13.03	624	200	282	434	72,2	139,7	38	59,7	51	51	13,6
	HUDC3010	254	40.97	13.03	1040	332	384	638	72,2	139,7	38	59,7	51	51	18,1
50 Tonne	HUDC5002	50	66.45	22.12	337	112	180	230	92,0	190,5	54	75,1	51	51	15
	HUDC5004	100	66.45	22.12	675	225	231	331	92,0	190,5	54	75,1	51	51	18,6
	HUDC5006	152	66.45	22.12	1013	337	282	434	92,0	190,5	54	75,1	51	51	22,6
	HUDC5010	254	66.45	22.12	1689	563	384	638	92,0	190,5	54	75,1	51	51	29,5
75 Tonne	HUDC7502	50	98.25	40.13	499	203	245	295	111,9	228,6	70	86,0	64	51	23,5
	HUDC7504	100	98.25	40.13	998	407	295	395	111,9	228,6	70	86,0	64	51	31,8
	HUDC7506	152	98.25	40.13	1497	611	346	498	111,9	228,6	70	86,0	64	51	38,6
	HUDC7510	254	98.25	40.13	2495	1019	448	702	111,9	228,6	70	86,0	64	51	45,3
100 Tonne	HUDC10002	50	139.29	48.45	707	246	257	307	133,2	279,4	89	107,6	64	51	42,1
	HUDC10004	100	139.29	48.45	1415	492	308	408	133,2	279,4	89	107,6	64	51	49
	HUDC10006	152	139.29	48.45	2123	738	359	511	133,2	279,4	89	107,6	64	51	56
	HUDC10010	254	139.29	48.45	3539	1230	461	715	133,2	279,4	89	107,6	64	64	65
150 Tonne	HUDC15002	50	193.55	70.96	1004	295	257	307	157,0	304	89	125,0	64	51	52,1
	HUDC15004	100	193.55	70.96	2008	590	308	408	157,0	304	89	125,0	64	51	61,2
	HUDC15006	152	193.55	70.96	3012	885	359	511	157,0	304	89	125,0	64	51	71,6
	HUDC15010	254	193.55	70.96	5021	1475	461	715	157,0	304	89	125,0	64	64	81,6

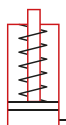

Threaded Cylinders

HT Series

- Ideal for frame pulling machines.
- Threaded plunger and base.
- Single acting cylinders with spring return.
- Removable threaded Plunger adapter for attaching accessories to plunger end and base.
- Maximum working pressure: 10,000 psi / 700 bar.



HT Series

80% **Safety Practices**
 Good industry practice recommends not exceeding 80% of maximum rated capacities of all our products.

Combo Kits
 Most cylinders are available in easy to order kits: cylinder, gauge, couplers, hose and pump.

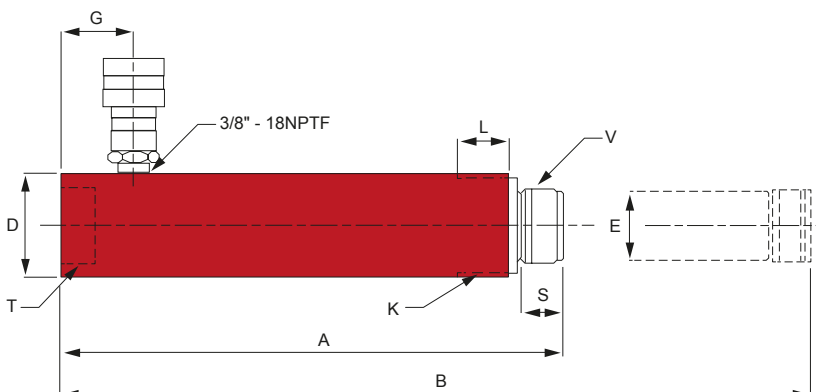

Cylinder Capacity	Stroke (mm)	Model Number	Cylinder Effective Area (cm ²)	Oil Capacity (cc)	Collapsed Height A (mm)	Extended Height B (mm)	Weight (kg)
10 Tonne 100 kN	151	HT1006	14.5	218	291	442	4.8
	253	HT1010	14.5	365	393	646	6.4
20 Tonne 228 kN	131	HT2005	33.2	421	299	430	10.0

Model Number	Outside Dia. D (mm)	Plunger Dia. E (mm)	Base to Inlet Port G (mm)	Collar K	Collar Thread Length L (mm)	Saddle Height S (mm)	Base Threads T	Plunger Threads V
HT1006	57	38	42	2¼"-14UN	29	24	1¼" -11.5 NPSM	1¼" -11.5 NPSM
HT1010	57	38	42	2¼"-14UN	29	24	1¼" -11.5 NPSM	1¼" -11.5 NPSM
HT2005	85	57	47	3½"-12UN	50	36	2" -11.5 NPTF	2" -11.5 NPTF

- H
- HD
- HL
- HF
- HLN
- HLNF
- HG
- HDG
- HC
- HDC
- HU
- HDU
- HULN
- HUC
- HUCD
- HT
- HP
- HPD
- Cylinder accessories

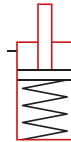

Pull Cylinders

HP Series - High-Tonnage Pulling



- High strength steel construction
- One piece high grade alloy bearing for side load protection and longer life
- Polyurethane cup seal provides optimum performance
- External plunger threads and Internal base threads
- Used for pulling and tensioning
- Maximum working pressure: 10,000 psi / 700 bar
- Spring extend return

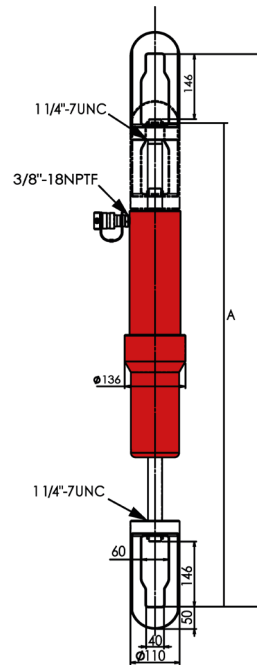
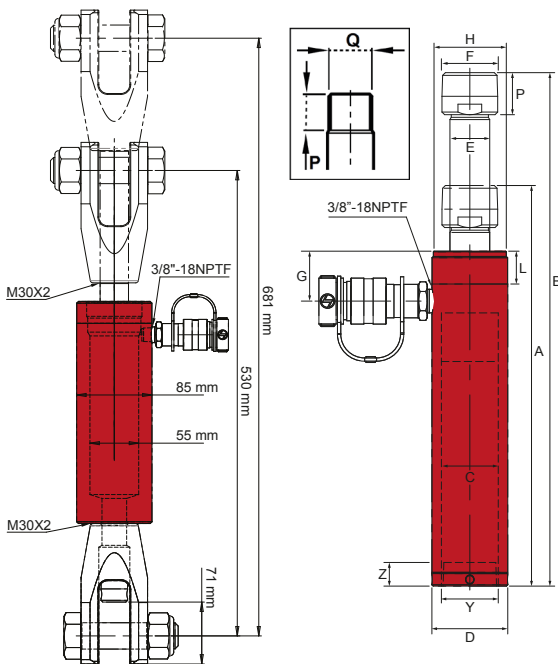

HPB3006A

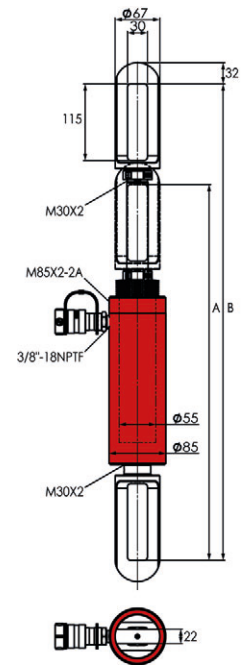

HPB1006A

Cylinder Capacity	Stroke (mm)	Model Number	Cylinder Effective Area (cm ²)	Oil Capacity (cc)	Collapsed Height A (mm)	Extended Height B (mm)	Outside Dia. D (mm)	Cylinder Bore Dia. C (mm)	Top to Inlet Port G (mm)	Collar	
										Thread H	Thread Length L (mm)
2.5 Tonne / 25 kN	127	HP0205	3.6	46	268	395	48	29	42	1 1/2"-16UN	25
5 Tonne / 51 kN	141	HP0505	7.4	104	303	444	57	43	38	2 1/4"-14UN	25
10 Tonne / 108 kN	151	HP1006	15.7	237	299	450	85	55	38	M85x2	25
10 Tonne / 108 kN	150.6	HPB1006A	-	236.74	565	715.6	85	55	-	-	-
30 Tonne / 285 kN	154.5	HPB3006A	-	633.02	1085	1239.5	114.3	85	-	-	-

Model Number	Adapter		Plunger			Base Mounting Hole		Weight (kg)	Optional Clevis
	Thread F (mm)	Length P (mm)	Dia. E (mm)	Thread Length K (mm)	Thread Q (mm)	Thread Y	Depth Z (mm)		
HP0205	3/4"-14NPTF	29	19	19	M16 x 1.5	3/4"-14NPTF	18	2.9	CP02
HP0505	1 1/4"-11.5NPTF	32	30	24	M28 x 1.5	1 1/4"-11.5NPTF	24	4.2	CP05
HP1006	-	-	32	26	M30 x 2	M30x2	25	9.5	CP10
HPB1006A	-	-	-	-	-	-	-	12.0	-
HPB3006A	-	-	-	-	-	-	-	47.4	-

Precision Double Acting Cylinders

HPD Series - High-Cycle Fixtured Application

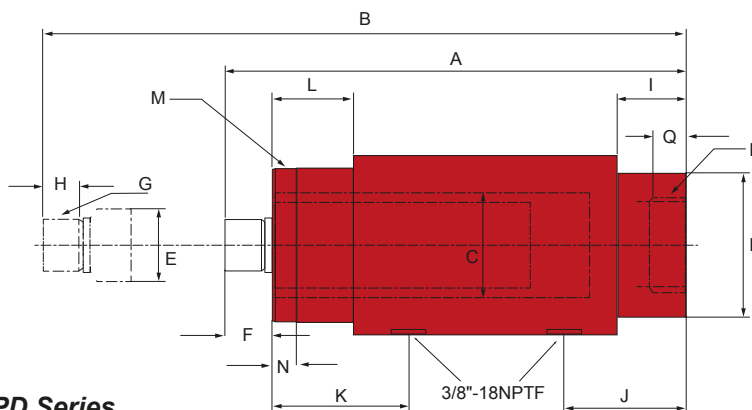
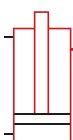

HPD Series

*Note: Precision double acting cylinders do not come with couplers.

- Provides hydraulic power for both extend and retract
- Designed for high cycle production applications
- High strength steel construction from gun drilled solid bar
- Plunger wiper seals keep dirt and contamination out
- Clevis eye attachments are available
- Maximum working pressure: 10,000 psi / 700 bar



Related Product: Hoses

We offer a variety of hoses, fittings, lengths and materials.

pg 73

Cylinder Capacity	Stroke (mm)	Model Number	Push Effective Area (cm ²)	Pull Effective Area (cm ²)	Collapsed Height A (mm)	Extended Height B (mm)	Cylinder Bore Dia. C (mm)	Outside Dia. D (mm)
8 Tonne 78 kN	155	HPD0906	11.4	6.5	350	505	38	64
	257	HPD0910	11.4	6.5	452	709	38	64
15 Tonne 139 kN	159	HPD1606	20.3	10.1	389	548	51	76
	260	HPD1610	20.3	10.1	490	750	51	76

Model Number	Plunger				Base to Inlet Port J (mm)	Top to Return Port K (mm)	Collar					Weight (kg)
	Dia. E (mm)	Protrusion F (mm)	Thread G	Thread Length H (mm)			Length L (mm)	Thread M	Thread Length N (mm)	Int. Base Thread P	Int. Base Thread Length Q (mm)	
HPD0906	25	25	3/4"-16N	19	38	56	38	2"-12N	15	1-1/16"-18N	35	6.6
HPD0910	25	25	3/4"-16N	19	38	56	38	2"-12N	15	1-1/16"-18N	35	8.4
HPD1606	36	29	1 1/8"-12N	25	54	73	54	2 3/8"-16N	25	2-3/16"-16N	41	10.0
HPD1610	36	29	1 1/8"-12N	25	54	73	54	2 3/8"-16N	25	2-3/16"-16N	41	12.8

Accessories for HPD Cylinder

By attaching these accessories to a HPD cylinder, you gain the ability for pull applications. For use with the 8 or 15 Tonne HPD cylinders only.

Model Number	Dimensions (mm)						
	A	B	C	D	E	F	G
CEBN09	50.8	101.6	73.2	13.5	25.4	82.5	44.5
CEBN16	66.8	130	95.5	19.5	35	101.6	52.3
CEFN09	50.8	121	98.6	10	25.4	-	-
CEFN16	66.8	143	115.8	13.5	35	-	-
CEN09	2"-12N	76	63.5	7	12.7	-	-
CEN16	2-3/8"-16N	92	79.2	7	19	-	-
CED09	25	23	1-1/16"-18N	19	33	24	3/4"-16N
CED16	32	28	2-3/16"-16N	25	48	30	1 1/8"-12N

Base Mounting - CEBN

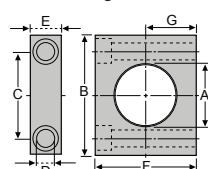

Flange Mounting - CEFN

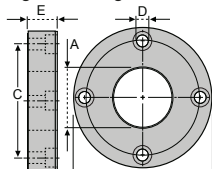

Retainer Nut - CEN

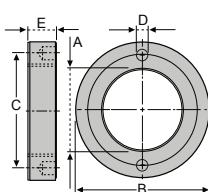

Clevis Eye - CED

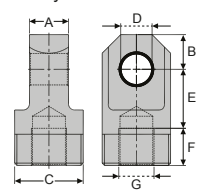



Cylinder Lifting Handles

- Designed for easy carrying cylinders.
- Provides better control when positioning cylinder.
- Easy installation.

Model Number	For Cylinders
LH25T34	H2504 through H2514
LH30T40	H3008, HD3008, HD3014, HC2002T, HC2006T, HU30XX
LH30T45	HC3002T, HC3006T, HDC3007, HDC3010
LH55T49	HLN5504 through HLN5512



LH25T34

Clevis and Tangs

CEB XX-Base

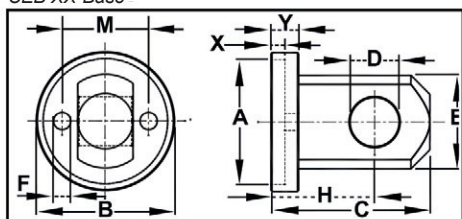

CEB-15



CEP XX-Plunger

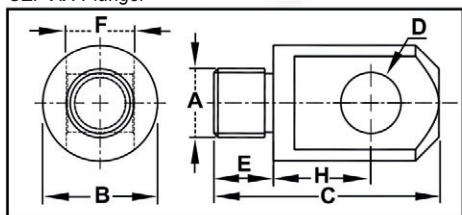

CEP-15



CPXX-Clevis Plunger & Base

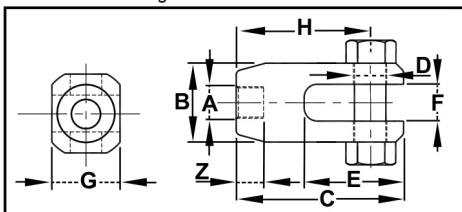

CP-10



Model Number	Cylinder Series	Model Number	Dimensions (mm)												
			A	B	C	D	E	F	G	H	M	X	Y	Z	
CEP05	Plunger	5	3/4"-16UNF	29	57	16	16	14	-	25.5	-	-	-	-	
CEP10		10 + 15	1"-8UNC	43	84	22	19	25	-	39.7	-	-	-	-	
CEP15		10 + 15	1"-8UNC	43	84	22	19	25	-	39.7	-	-	-	-	
CEP25		25	1 1/2"-16	57	97	32	22	38	-	42.8	-	-	-	-	
CEB05	Base	5		38.6	44	54	16	29	6.5	-	38.0	26	6.4	12.7	-
CEB10		10		58.0	63	73	22	43	8.2	-	47.6	38	6.4	12.7	-
CEB15		15		70.4	76	73	22	43	9.7	-	47.6	48	6.4	12.7	-
CEB25		25		86.2	95	86	32	57	14.3	-	54.0	58	6.4	12.7	-
CP02*	"Plunger & Base"	Only HP0205	Male 3/4"-14NPT Female M16X1,5	40	85	16	55	20	40	65	-	-	-	22	
CP05*		Only HP0505	Male 1 1/4"-NPT Female M28X1,5	48	100	20	70	20	48	75	-	-	-	25	
CP10*		Only HP1006	M30x2	75	160	30	95	35	65	128	-	-	-	27	

* 2-pc set with an adaptor

Cylinder Bases

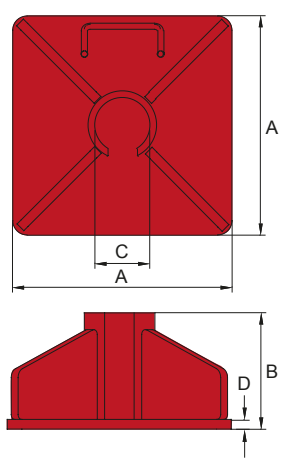

Model Number	For use with Cylinder Series	Dimensions (mm)			
		A	B	C	D
CB05	H05 (Except H0501)	200	118	39	8
CB10	H10 (except H1001)	230	120	58	10
CB15	H15	254	122	70	12
CB25	H25	280	126	87	16
CB55	H55	304	162	132	12

Cylinder Saddles

Grooved, Tilt, and Threaded

Safety Instructions
Visit our DO'S and DON'TS section to review the best methods of operation. Always be prepared.

102
pg



SDT Series



SDTG Series



SDTL Series



SD Series



HTD10



APS Series

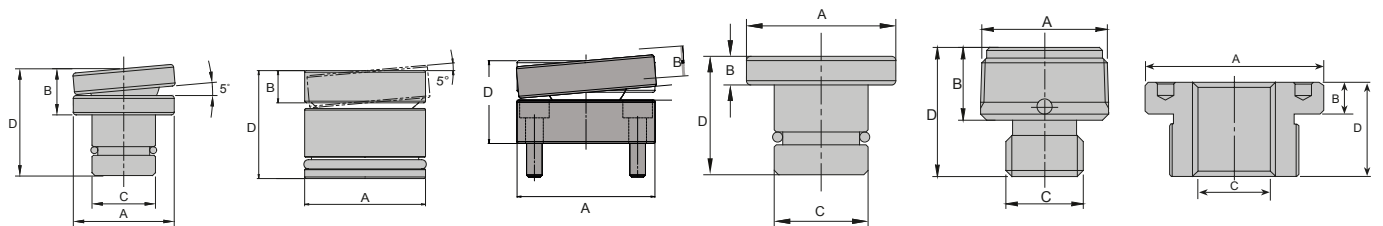

Saddle Type	Model Number	For Cylinder(s)	Dimensions (mm)			
			A	B	C	D
Tilt	SDT05	H05	25	17	17	31
	SDT10	H10*	35	16.2	22	37.2
	SDT15	H15	38	18.9	22	39.9
	SDT25	H25 / H3008	50	18.6	35.5	40.6
	SDT55	H55, HD55, H75, HD75, H100, HU55, HU100, HLN55 and HLN100	70	21.4	71	32.8
	SDT200	HLN150 and HLN200	130	28.8	130	45
	SDT250	HLN250	150	29.5	150	46
	SDT300	HLN300	195	83.8	139	100
	SDTG100	HG100 and HDG100	75	20	-	67
	SDTG150	HG150 and HDG150	94	19.5	-	68.8
	SDTG200	HG200 and HDG200	113	28	-	82.5
	SDTL10	HL1001	35	10	-	21
	SDTL50	HL2002, HL3002, HL5002	50	14	-	29
SDTL100	HL10002	71	18	-	35	
Grooved	SD05	H05	25	6	17	20.5
	SD10	H10*	35	6	22	27
	SD15	H15	38	7	22	30
	SD25	H25	50	6.5	35.5	29
Threaded	HTD10	HT1006, HT1010 and HP0505 H1002-H1014, HD1010-HD1012	1 1/4"- 11.5NPT	26.5	1"- 8UNC	45
Hollow threaded	APS20	HC20	55	10	1"- 8UNC	20.5
	APS30	HC30	63	10	1 1/4" - 7UNC	27
	APS60	HC60	92	13	1 5/8" - 5.5UNC	30

* Except H1001

- H
- HD
- HL
- HF
- HLN
- HLNF
- HG
- HDG
- HC
- HDC
- HU
- HDU
- HULN
- HUC
- HUCD
- HT
- HP
- HPD

Cylinder accessories



Hand Pump Matching Chart

Hand Pumps

- Match up the stroke length to the capacity of your cylinder to find the suggested hand pump to go with your cylinder.

Stroke (mm)	Capacity							
	5 Tonne 45 kN	10 Tonne 101 kN	15 Tonne 141 kN	25 Tonne 232 kN	30 Tonne 287 kN	50 Tonne 495 kN	75 Tonne 726 kN	95 Tonne 929 kN
25.4	1.00	2.24	3.14	5.14	6.49	10.99	16.10	20.57
50.8	2.00	4.48	6.28	10.28	12.98	21.98	32.20	41.14
76.2	3.00	6.72	9.42	15.42	19.47	32.97	48.30	61.71
101.6	4.00	8.96	12.56	20.56	25.96	43.96	64.40	82.28
127.0	5.00	11.20	15.70	25.70	32.45	54.95	80.50	102.85
152.4	6.00	13.44	18.84	30.84	38.94	65.94	96.60	123.42
177.8	7.00	15.68	21.98	35.98	45.43	76.93	112.70	143.99
203.2	8.00	17.92	25.12	41.12	51.92	87.92	128.80	164.56
228.6	9.00	20.16	28.26	46.26	58.41	98.91	144.90	185.13
254.0	10.00	22.40	31.40	51.40	64.90	109.90	161.00	205.70
304.8	12.00	26.88	37.68	61.68	77.80	131.88	193.20	246.84
330.2	13.00	29.12	40.82	66.82	84.37	142.87	209.30	267.41
355.6	14.00	31.36	43.96	71.96	90.86	153.86	225.40	287.98
Suggested* Hand Pump Models	P350 P601S	P1000 P1201		P2301 P2301M		P4301		P8701 P8701M



















*The suggested pump model is based on oil capacity requirements of the cylinder.

Matching Chart

Air, Electric and Gas Engine Pumps

- Match up the stroke length and capacity of the cylinder to find the suggested pump to work with your application.

Stroke (mm)	Capacity							
	5 Tonne 45 kN	10 Tonne 101 kN	15 Tonne 141 kN	25 Tonne 232 kN	30 Tonne 287 kN	50 Tonne 495 kN	75 Tonne 726 kN	95 Tonne 929 kN
25.4	1.00	2.24	3.14	5.14	6.49	10.99	16.10	20.57
50.8	2.00	4.48	6.28	10.28	12.98	21.98	32.20	41.14
76.2	3.00	6.72	9.42	15.42	19.47	32.97	48.30	61.71
101.6	4.00	8.96	12.56	20.56	25.96	43.96	64.40	82.28
127	5.00	11.20	15.70	25.70	32.45	54.95	80.50	102.85
152.4	6.00	13.44	18.84	30.84	38.94	65.94	96.60	123.42
177.8	7.00	15.68	21.98	35.98	45.43	76.93	112.70	143.99
203.2	8.00	17.92	25.12	41.12	51.92	87.92	128.80	164.56
228.6	9.00	20.16	28.26	46.26	58.41	98.91	144.90	185.13
254	10.00	22.40	31.40	51.40	64.90	109.90	161.00	205.70
304.8	12.00	26.88	37.68	61.68	77.80	131.88	193.20	246.84
330.2	13.00	29.12	40.82	66.82	84.37	142.87	209.30	267.41
355.6	14.00	31.36	43.96	71.96	90.86	153.86	225.40	287.98
Suggested Air/Electric/ Gas Pump Models	PA600	PA1500 PA2000			PA3801 PA7550 PE30		PE40 PE50 PD70/PG70 PE60	

Power Source	Pump Type	Image	Page Number / Reference Image
Manual	Single Speed Metal Hand Pump (P-Series)		48-49
	Two Speed Metal Hand Pumps (P-Series)		
	Two Speed Aluminum Hand Pumps (P-Series)		
	Double Acting Hand Pumps (P-Series)		
	Foot Pump (P57-Series)		
Air	All-Direction Air Pump (PA-Series)		51
	Air Pumps (PA-Series)		50-53
	Double Acting Air Pump (PA-Series)		
	Remote Control Air Pump (PA-Series)		
	Rotary Air Pumps (PAR-Series)		54
Electric	Universal Motor Pumps (PU-Series)		55
	Single Phase Electric Pumps		56-60
	PE30 0.5 HP Electric Pumps		
	PE40 1 HP Electric Pumps		
	PE50 1.5 HP Electric Pumps		61
	PE60 3 HP Electric Pumps		
Gas	PG70 5.5 HP Gas Engine Pump		62-63
	PD70 4.6 HP HATZ Diesel Engine Pump		

Control Valves and Accessories	Page 64 ▶
Pumps-Cylinder Combo's	Page 65 ▶



Hand Pumps

Aluminum and Steel



P Series

Combo Kits
Most hand pumps are available in easy to order kits; Pump, Gauge, Couplers, Hose and Cylinder pg 64

Related Product: Gauges
Reduce the risk of overloading your product by using a gauge. A variety of graduations and types to suit any need. pg 71

Safety Instructions
Visit our DO'S and DON'TS section to review the best methods of operation. Always be prepared. pg 102

Product Information

- Metal reservoirs resist cracking.
- Internal pressure relief valve for overload protection.
- Perfect for use with cylinders and hydraulic tools or OEM applications.
- Two-Speed pumps reduce user fatigue and increase productivity.

CE

Model Number	Usable Oil Capacity (cc)	Oil Outlet Port	Pressure Rating/Oil Displacement per Stroke		Piston Stroke (mm)	Handle Operating Force (N)	Reservoir Construction
			1 st Stage (BAR/cc)	2 nd Stage (BAR/cc)			
Single Speed - Single Acting							
P601S	600	3/8"-18 NPTF	-	700/2.5	20	485	Steel
2-Speed - Single Acting							
P350*	350	1/4"-18 NPTF	14/3	700/0.8	10	391	Aluminum
P352	352	3/8"-18 NPTF	14/3	700/0.8	10	391	Aluminum
P1000	1000	3/8"-18 NPTF	14/13.3	700/2.3	21	440	Aluminum
P1201	1100	3/8"-18 NPTF	14/13.3	700/2.3	27	440	Steel
P2301	2200	3/8"-18 NPTF	14/13.3	700/2.3	21	440	Steel
P2801	2870	3/8"-18 NPTF	30/46	700/3.9	27	468	Steel
P4301	4100	3/8"-18 NPTF	14/13.3	700/2.3	21	440	Steel
P8701	7800	3/8"-18 NPTF	20 /120	700/4.7	43	400	Steel
2-Speed - Double Acting							
P2301M	2200	3/8"-18 NPTF	14/13.3	700/2.3	21	440	Steel
P2801M	2700	3/8"-18 NPTF	14/13.3	700/2.3	21	440	Steel
P4301M	4100	3/8"-18 NPTF	30/46	700/3.9	27	468	Steel
P8701M	7800	3/8"-18 NPTF	20/120	700/4.7	43	400	Steel

*CA3814 not included. Needs to be ordered separately

P350, P352, P1000, P601S, P1201

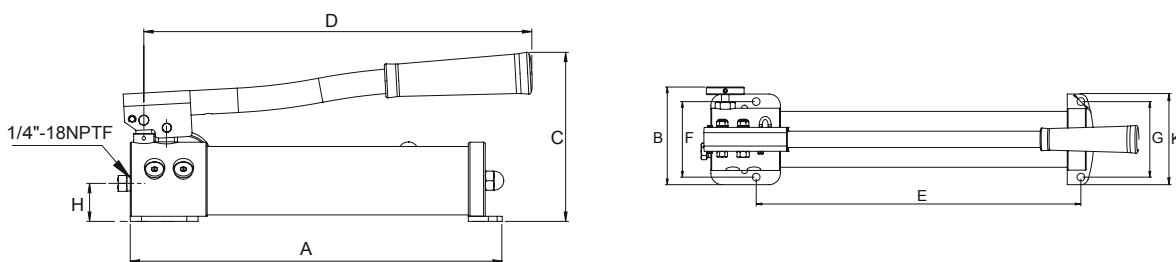

P2301(M), P2801(M), P4301(M)

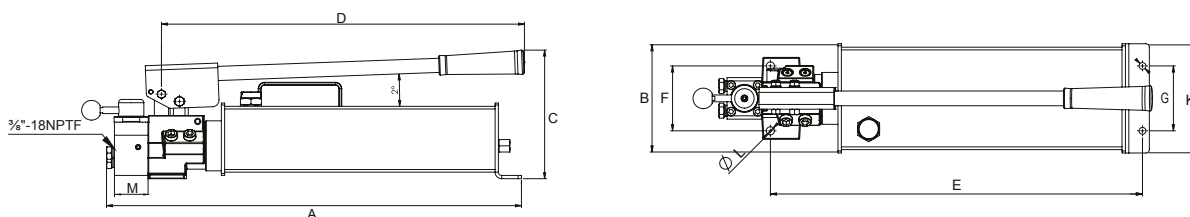

P8701, P8701M

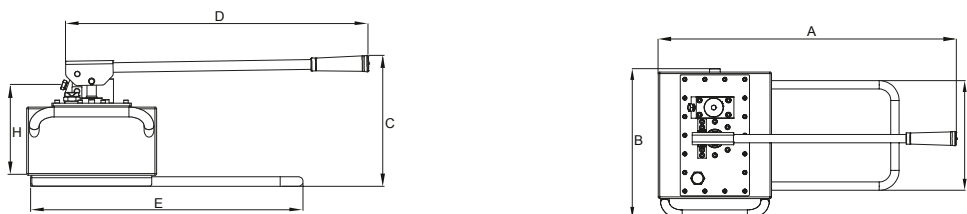

Model Number	Dimensions (mm)												Weight w/Oil (kg)
	A	B	C	D	E	F	G	H	J	K	L	M	
Single Speed - Single Acting													
P601S	506	148	160	530	542	100	95	32	115	115	12	-	5.9
2-Speed - Single Acting													
P350*	360	98	160	360	303	75	65	32	85	85	8	-	3
P352	360	98	160	360	306	75	65	32	85	85	8	-	3
P1000	584	124	175	576	430	100	100	32	120	120	10	-	6.2
P1201	586	135	182	580	540	95	95	44	115	115	10	-	9.3
P2301	609	135	173	563	573	95	90	44	120	110	10	-	12.6
P2801	674	135	183	661	592	89	89	35	120	135	7	-	13.8
P4301	586	160	195	565	545	95	95	44	120	160	10	-	17.1
P8701	771	388	295	684	-	-	-	210	-	284	-	-	34.5
2-Speed - Double Acting													
P2301M	696	120	173	552	573	95	90	41/27	120	110	10	50	14.7
P2801M	724	135	183	652	592	89	89	39/36	120	135	7	50	14.7
P4301M	619	160	196	552	545	95	95	39/36	120	160	10	50	19
P8701M	771	388	295	684	-	-	-	210	-	284	-	-	35.1

* CA3814 adapter excluded

Manual Pumps

Air Pumps

Rotary Air pumps

Electric Pumps

Torc wrench pump

3 Phase Pump

Gas/ Diesel Pumps

Pump & Cylinder sets

1500 BAR



Foot Pump

P57 Series - 10,000 PSI



P570FP

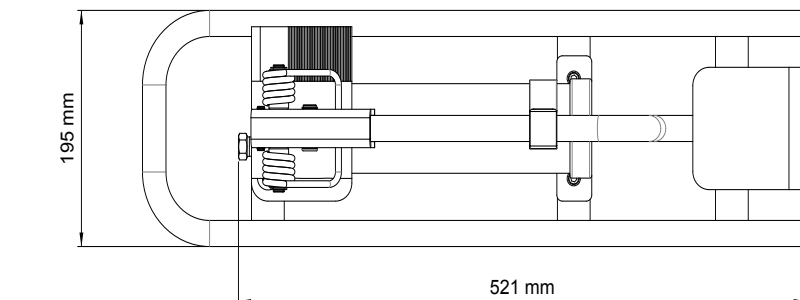
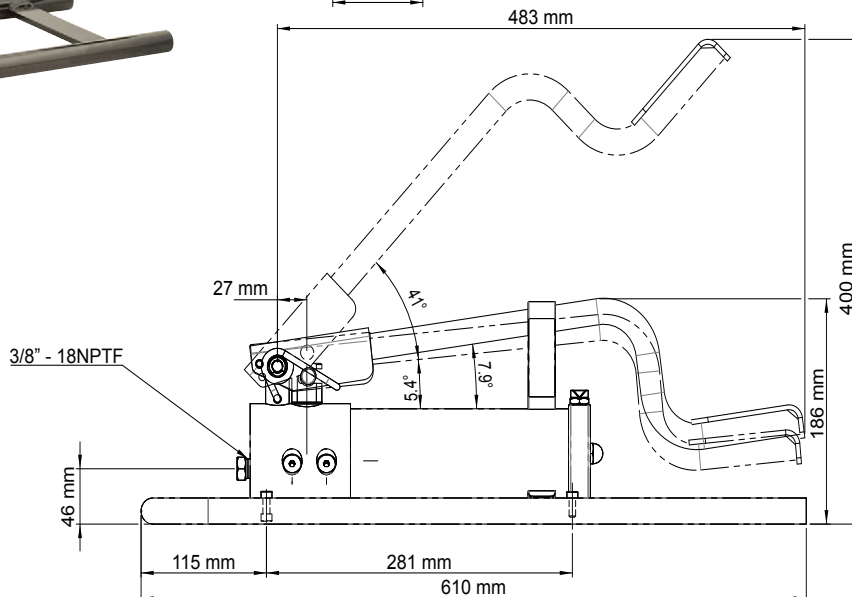
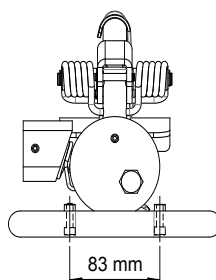

Safety Practices

Good industry practice recommends not exceeding 80% of maximum rated capacities of all our products.



HF Kits

Consider using our portable HF kits in conjunction with this pump.

pg 19



Safety Instructions

Visit our DO'S and DON'TS section to review the best methods of operation. Always be prepared.

pg 100



High-Flow Couplers

High-Flow Coupler: CH38F is included on all models (except where specified).

Related Product: Nut Splitters

The nut splitters pair up with this portable foot pump. Our hydraulic nut splitters come in a spacious tool box so its easy to carry around from site-to-site. This tool box is large enough to hold small cylinders, saddles, spacers or whatever tool you need to bring with you to your next job site.



Model Number	Bolt Range	Hexagon Nut Range
NS1319	6-12	13-19
NS1924	12-16	19-24
NS2432	16-22	24-32
NS3241	22-27	32-41
NS4150	27-33	41-50
NS5060	33-39	50-60
NS6075	39-48	60-75

pg 84

Model Number	Usable Oil (cc)	Oil Outlet Port	Pressure Rating (BAR)		Oil Displacement per Stroke (cc)		Max. Handle Effort (kg)	Piston Stroke (mm)	Weight (kg)
			1st Stage	2nd Stage	"1st Stage"	2nd Stage			
P570FP	500	3/8"-18 NPTF	13.8	690	13	2	57.7	21	8.2

All Position Aluminium Pumps

- Pump can work in any position.
- Mounting plate allows the pump to be securely fastened.



PA600

360°

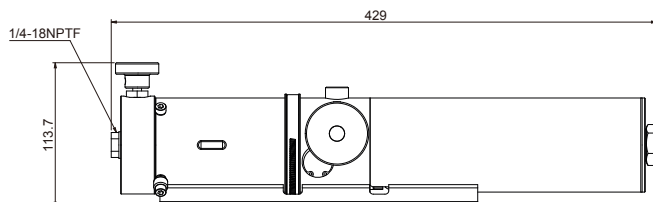
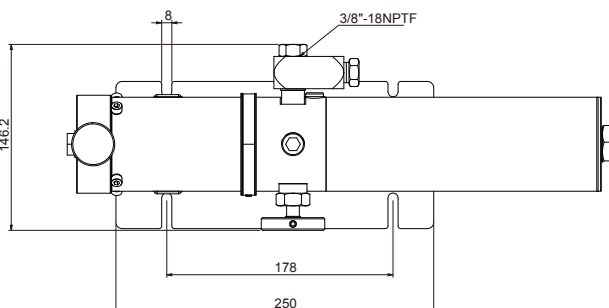
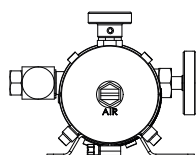
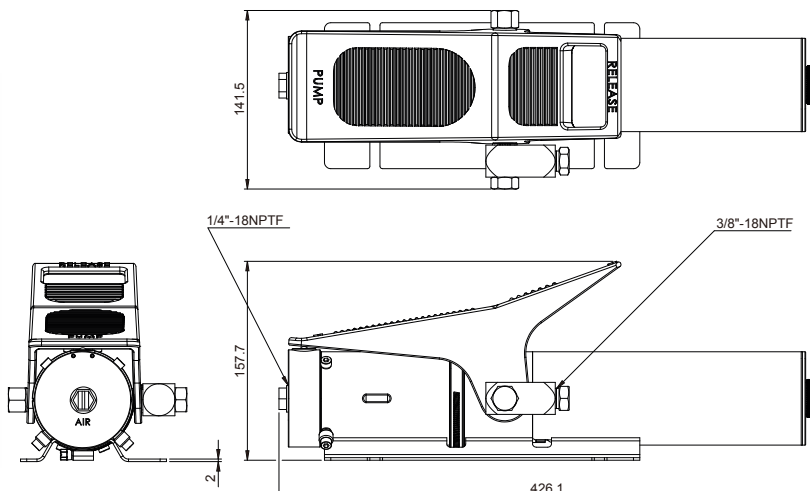

PA600H

360°

Model Number	Usable Oil Capacity (cc)*	Oil Outlet Port	Output Flow Rate		Input Air Pressure Required (BAR)	Air Consumption (L/min)	Reservoir Construction
			No Load (L/min)	Load (L/min)			
Single Acting							
PA600	600	3/8"-18 NPTF	1.00	0.15	8.0 - 14.0	220	Aluminum
PA600H	600	3/8"-18 NPTF	1.00	0.15	8.0 - 14.0	220	Aluminum

* Oil capacity varies by position. Pump can be mounted outlet up or down

For sizes: PA600 & PA600H - Page 49

- Manual Pumps
- Air Pumps
- Rotary Air pumps
- Electric Pumps
- Torc wrench pump
- 3 Phase Pump
- Gas/ Diesel Pumps
- Pump & Cylinder sets
- 1500 BAR



Air Pumps

Air Actuated Power

PA Series



PA1500



PA600H



PA600

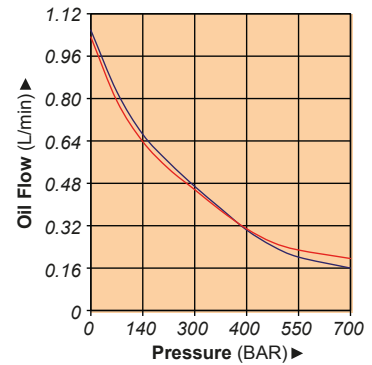

Air Consumption = 220.87 L/min



PA2000

PA3801

PA7550

Product Information

- Metal reservoirs resist cracking
- US Patent No. 5,946,912, a built in bypass device protects the hydraulic system from over pumping damage
- A compact yet powerful Air Turbo Motor US Patent No. 5,341,723
- Suggested air inlet range: 110-175 psi / 7.6-12.1 bar
- Maximum working pressure: 10,000 psi / 700 Bar



PA7550M

PA3801M

PA1500M

PA1500A Pressure Adjustment



PA1500A Pressure can be adjusted externally from 1,000 psi / 70 Bar to 10,000 psi / 700 Bar.

Model Number	Usable Oil Capacity (cc)	Oil Outlet Port	Output Flow Rate		Input Air Pressure Required (BAR)**	Air Consumption (L/min)	Reservoir Construction
			No Load (L/min)	Load (L/min)			
Single Acting							
PA600	600	3/8"-18 NPTF	1.00	0.15	8.0 - 14.0	220	Aluminum
PA600H	600	3/8"-18 NPTF	1.00	0.15	8.0 - 14.0	220	Aluminum
PA1500	1500	3/8"-18 NPTF	1.08	0.18	8.0 - 14.0	220	Aluminum
PA1500A (*)	1500	3/8"-18 NPTF	1.08	0.18	8.0 - 14.0	220	Aluminum
PA1500L (**)	1500	3/8"-18 NPTF	1.00	0.16	8.0 - 14.0	220	Aluminum
PA1500LA (*)(**)	1500	3/8"-18 NPTF	1.08	0.18	8.0 - 14.0	220	Aluminum
PA2000	2000	3/8"-18 NPTF	1.07	0.20	8.0 - 14.0	220	Aluminum
PA3801	3800	3/8"-18 NPTF	1.07	0.18	8.0 - 14.0	220	Steel
PA3801L (**)	3800	3/8"-18 NPTF	1.00	0.16	8.0 - 14.0	220	Steel
PA7550	7550	3/8"-18 NPTF	1.07	0.18	8.0 - 14.0	220	Steel
PA7550L (**)	7550	3/8"-18 NPTF	1.07	0.18	8.0 - 14.0	220	Steel
Double Acting							
PA1500M	1500	3/8"-18 NPTF	1.08	0.18	8.0 - 14.0	220	Aluminum
PA3801M	3800	3/8"-18 NPTF	1.07	0.18	8.0 - 14.0	220	Steel
PA7550M	7550	3/8"-18 NPTF	1.07	0.18	8.0 - 14.0	220	Steel

* This unit is equipped with an external pressure adjustment (70-700 bar)

**These pumps are equipped with a hand held air powered pendant

*** Air active pressure for oil operating 0-700 bar

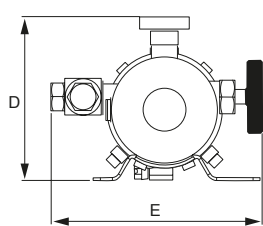
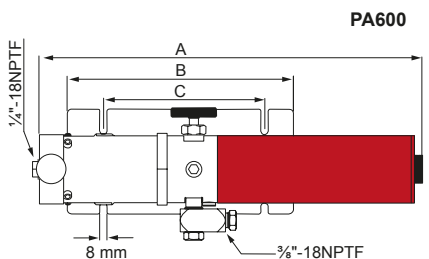

PA Series

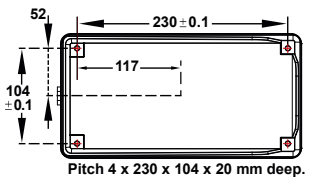
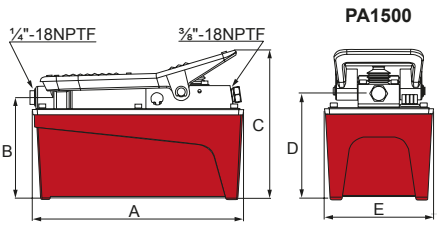

PA1500L

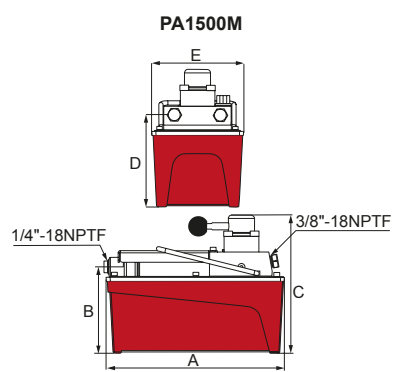
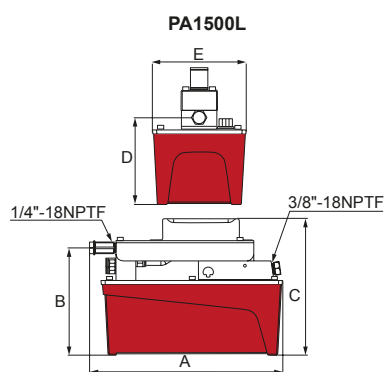

Air Pump Combo
 PA1500 air pumps are available in easy to order kits: pump, gauge, coupler, hose and cylinder
 pg 60

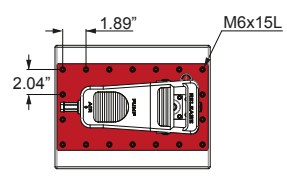
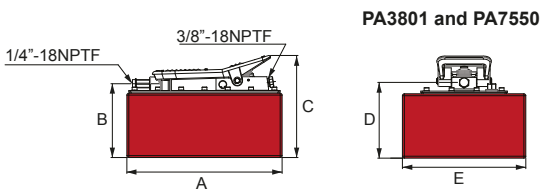

Related Product: Hoses
 We offer a variety of hoses, fittings, lengths and materials.
 pg 73

Model Number	Base Mounting Holes	Dimensions (mm)					Weight w/Oil (kg)
		A	B	C	D	E	
Single Acting							
PA600	yes	426	250	178	157	142	6.4
PA600H	yes	426	250	178	114	146	5.7
PA1500	yes	263	127	185	131	136	8.2
PA1500A (*)	yes	263	127	185	131	136	8.2
PA1500L (**)	yes	278	160	204	130	136	8.8
PA1500LA (*)(**)	yes	263	127	185	131	136	8.2
PA2000	yes	292	152	203	132	151	9.1
PA3801	no	329	129	187	133	187	12.3
PA3801L (**)	no	329	205	207	132	187	13.8
PA7550	no	329	153	211	156	255	16.3
PA7550L (**)	no	329	153	211	156	255	16.3
Double Acting							
PA1500M	yes	267	127	203	136	136	8.7
PA3801M	no	329	129	204	135	187	10.9
PA7550M	no	329	153	229	161	255	18.1

* Unit is equipped with an external pressure adjustment (70-700 bar)
 **These pumps are equipped with a hand held air powered pendant

- Manual Pumps
- Air Pumps**
- Rotary Air pumps
- Electric Pumps
- Torc wrench pump
- 3 Phase Pump
- Gas/ Diesel Pumps
- Pump & Cylinder sets
- 1500 BAR



Rotary Air Pumps

PUAR Series - 10,000 PSI Rated

Related Product: Gauges
Reduce the risk of overloading your product by using a gauge. A variety of graduations and types to suit any need. pg 71



Related Product: Hoses
We offer a variety of hoses, fittings, lengths and materials. pg 73



Will be delivered without Hydraulic Oil





PUARM4003

PUARD1701

PUARD1703

PUAR Series

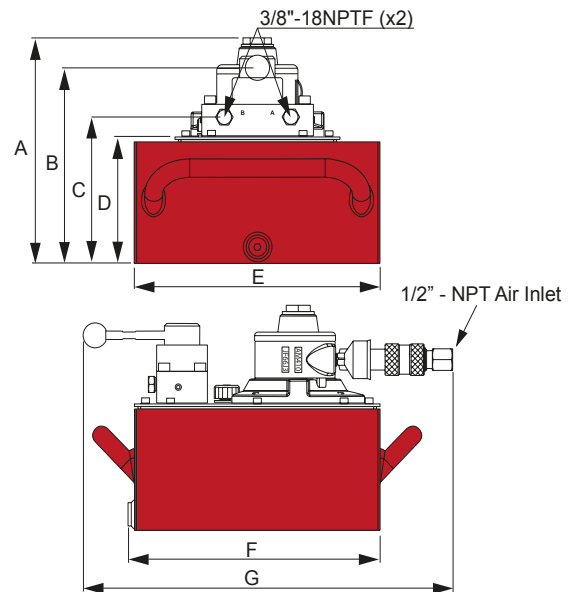
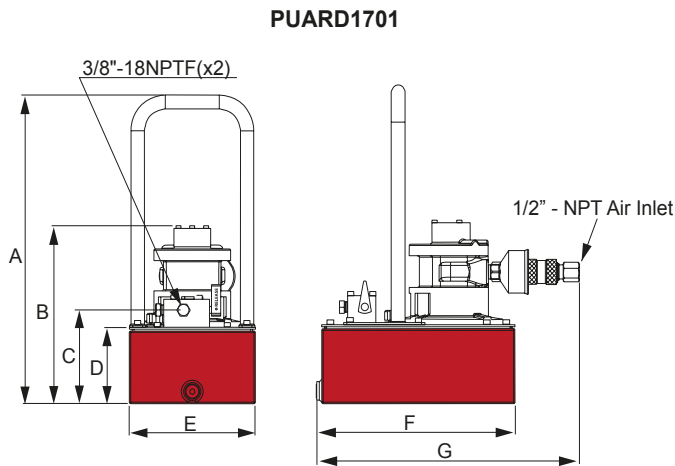
PUAR1703 and PUAR4003



Used with Cylinder	Motor Size (hp)	Usable Oil Capacity (cc)	Model Number	Pressure Rating (BAR)	Pressure Rating		Oil Output Flow Rate		Valve Type	Valve Function	Air Pressure Range (BAR)
					1 st Stage (BAR)	2 nd Stage (BAR)	1 st Stage (L/min)	2 nd Stage (L/min)			
Single Acting	1.7	3800	PUARD1701	700	48.30	700	5.13	0.36	Dump	Advance/Return	4.14~5.52
	1.7	11400	PUARD1703	700	48.30	700	5.13	0.36	Dump	Advance/Return	4.14~5.52
	4	11400	PUARD4003	700	48.30	700	7.62	1.15	Dump	Advance/Return	4.14~0.69
	1.7	11400	PUAR1703	700	48.30	700	6.83	0.36	Manual PUW3	Advance/Hold/Return	4.14~5.52
	4	11400	PUAR4003	700	48.30	700	8.39	1.15	Manual PUW3	Advance/Hold/Return	4.14~0.69
Double Acting	1.7	11400	PUARM1703	700	48.30	700	6.83	0.36	Manual PUW4	Advance/Hold/Return	4.14~5.52
	4	11400	PUARM4003	700	48.30	700	8.39	1.15	Manual PUW4	Advance/Hold/Return	4.14~0.69

Model Number	Air Consumption (L/min)	Max Sound Level (dBA)	Dimensions (mm)							Weight (kg)
			A	B	C	D	E	F	G	
PUARD1701	1246	93	485	239	147	120	205	313	404	19.1
PUARD1703	1246	93	-	304	212	185	305	313	456	24.5
PUARD4003	2690	100	-	344	212	185	305	313	467	29.9
PUAR1703	1246	93	303	267	209	185	305	313	459	24.9
PUAR4003	2690	100	344	267	209	185	305	313	470	30.4
PUARM1703	1246	93	303	267	209	185	305	313	459	24.9
PUARM4003	269	100	-	344	209	185	305	313	470	26.9

Universal Motor Pumps

PU Series - Light-Weight Pumps



PU20M4N01C

- Portable, light weight and compact design.
- Universal Motor, starts under full load and is available in either 120VAC 50/60 HZ or 240VAC 50/60HZ.
- 3mt 24 VAC pendant control for safety.
- Weighs only 17 kg. with oil.
- External pressure adjustment is available.
- Designed for intermittent duty operation.
- Gauge port on control valve.
- Reservoir Capacity 3.8L

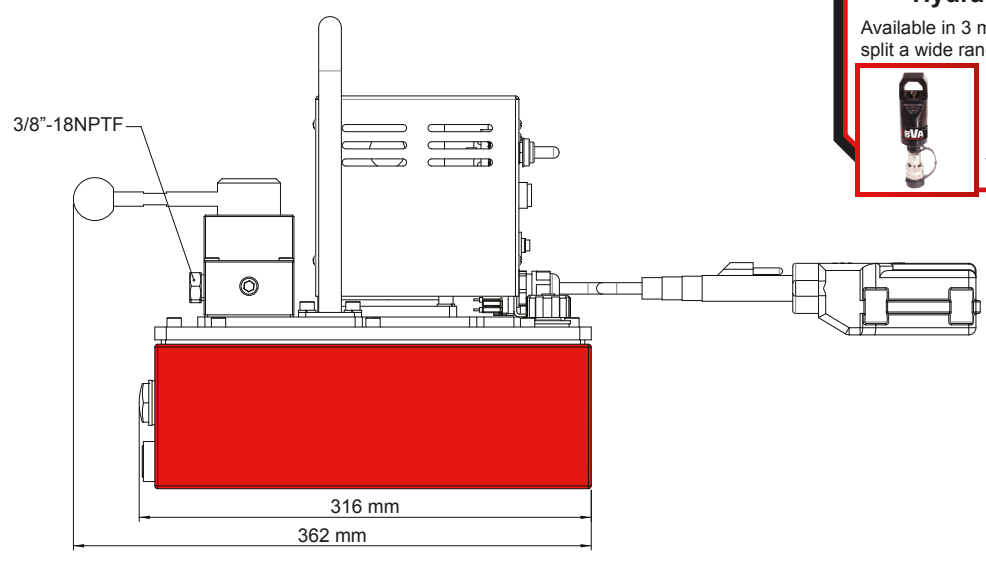
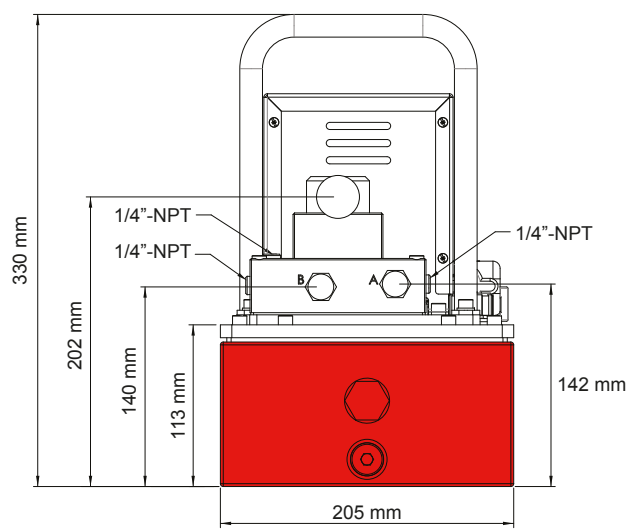

Hydraulic Gear Pullers

5, 10, 15, 25 & 50 Tonne Hydraulic Gear Pullers have a safety cage design to help keep the jaws tight to the gear and prevent slippage that can cause injury. Pair these with BVA's PU20M3N01B Lightweight e-pump for portability.



pg 83

Flange Spreaders

BVA's Pin Type Flange Spreaders are available in both 5 & 10 Tonne models and well suited for most environments. For portability and speed the PU20M4N01B would be an ideal choice.



pg 85

Hydraulic Nut Splitters

Available in 3 models, each nut splitter can split a wide range of nut sizes thereby reducing the number of splitters needed. The BVA PU20DMP01B dump style pump functions well with these splitters



pg 86

Manual Pumps

Air Pumps

Rotary Air pumps

Electric Pumps

Torc wrench pump

3 Phase Pump

Gas/ Diesel Pumps

Pump & Cylinder sets

1500 BAR

Valve Function	Flow Rate				Motor Size	Voltage 50/60 Hz		Weight (kg)	Length (mm)	Width (mm)	Height (mm)
	1st Stage		2nd Stage			120 VAC	240 VAC				
	L/min	BAR	L/min	BAR		Model #	Model #				
3W/3P Advance/Hold Return	2.18	62~76	0.46	700	1.0 Hp	PU20M3N01B	PU20M3N01C	16.8	362	205	300
4W/3P Advance/Hold/Return	2.18	62~76	0.46	700	1.0 Hp	PU20M4N01B	PU20M4N01C	16.8	362	205	300



Electric Pumps

PE30, PE40, PE50 and PE60 Series - Single Phase

- Meets OSHA regulations for sound (80dBA).
- 2 Stage pumps provide fast run up before the high pressure stage.
- Suction strainers screen out contamination to prevent pump damage.
- All units are wired as 240 VAC 50 Hz , and are IP54 rated.
- All hand pendants are wired 24 VAC for safety , and are IP65 rated.
- Starts under full load.









PE40M4U02D

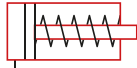
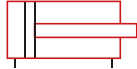

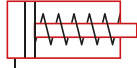
PEW03 Optional

Use with Cylinder Type	Flow Rate				Motor Size
	1 st Stage		2 nd Stage		
	L/min	BAR	L/min	BAR	

Manual Valve							
	3W/3P Advance /Hold Return		4.20	24	0.24	700	0.5 Hp
			4.20	48	0.49	700	1.0 Hp
			6.40	48	0,83	700	1.5 Hp
			7.10	48	1.50	700	3 Hp
	4W/3P Advance /Hold/Return		4.20	24	0.24	700	0.5 Hp
			4.20	48	0.49	700	1.0 Hp
			6.40	48	0,83	700	1.5 Hp
			7.10	48	1.50	700	3 Hp
Manual Valve w/3 meter Motor Pendant							
	3W/3P Advance /Hold Return		4.20	24	0.24	700	0.5 Hp
			4.20	48	0.49	700	1.0 Hp
			6.40	48	0,83	700	1.5 Hp
			7.10	48	1.50	700	3 Hp
	4W/3P Advance /Hold/Return		4.20	24	0.24	700	0.5 Hp
			4.20	48	0.49	700	1.0 Hp
			6.40	48	0,83	700	1.5 Hp
			7.10	48	1.50	700	3 Hp
Solenoid Valve w/3 meter Pendant							
	3W/3P Advance /Hold Return		4.20	24	0.24	700	0.5 Hp
			4.20	48	0.49	700	1.0 Hp
			6.40	48	0,83	700	1.5 Hp
			7.10	48	1.50	700	3 Hp
	4W/3P Advance /Hold/Return		4.20	24	0.24	700	0.5 Hp
			4.20	48	0.49	700	1.0 Hp
			6.40	48	0,83	700	1.5 Hp
			7.10	48	1.50	700	3 Hp



PE50M4U03D

PE30M4U01D



PE40S4U02D



PE60M4U15D

PE Series

80%

Safety Practices

Good industry practice recommends not exceeding 80% of maximum rated capacities of all our products.

Usable Oil Capacity				
1 Gal / 3.8 L	2 Gal / 7.6 L	3 Gal / 11.4 L	5 Gal / 19.4 L	16 Gal / 60 L
Model Number	Model Number	Model Number	Model Number	Model Number
Manual Valve				
PE30M3U01D	PE30M3U02D	PE30M3U03D	-	-
-	PE40M3U02D	PE40M3U03D	PE40M3U05D	PE40M3U15D
-	-	PE50M3U03D	PE50M3U05D	PE50M3U15D
-	-	-	PE60M3U05D	PE60M3U15D
PE30M4U01D	PE30M4U02D	PE30M4U03D	-	-
-	PE40M4U02D	PE40M4U03D	PE40M4U05D	PE40M4U15D
-	-	PE50M4U03D	PE50M4U05D	PE50M4U15D
-	-	-	PE60M4U05D	PE60M4U15D
Manual Valve w/3 meter Motor Pendant				
PE30W3U01D	PE30W3U02D	PE30W3U03D	-	-
-	PE40W3U02D	PE40W3U03D	PE40W3U05D	PE40W3U15D
-	-	PE50W3U03D	PE50W3U05D	PE50W3U15D
-	-	-	PE60W3U05D	PE60W3U15D
PE30W4U01D	PE30W4U02D	PE30W4U03D	-	-
-	PE40W4U02D	PE40W4U03D	PE40W4U05D	PE40W4U15D
-	-	PE50W4U03D	PE50W4U05D	PE50W4U15D
-	-	-	PE60W4U05D	PE60W4U15D
Solenoid Valve w/3 meter Pendant				
PE30S3U01D	PE30S3U02D	PE30S3U03D	-	-
-	PE40S3U02D	PE40S3U03D	PE40S3U05D	PE40S3U15D
-	-	PE50S3U03D	PE50S3U05D	PE50S3U15D
-	-	-	PE60S3U05D	PE60S3U15D
PE30S4U01D	PE30S4U02D	PE30S4U03D	-	-
-	PE40S4U02D	PE40S4U03D	PE40S4U05D	PE40S4U15D
-	-	PE50S4U03D	PE50S4U05D	PE50S4U15D
-	-	-	PE60S4U05D	PE60S4U15D

- Manual Pumps
- Air Pumps
- Rotary Air pumps
- Electric Pumps
- Torc wrench pump
- 3 Phase Pump
- Gas/ Diesel Pumps
- Pump & Cylinder sets
- 1500 BAR



Electric Pumps

Electric Power Source



PE30M4U01D



PE60M4U15D

PE30 Series

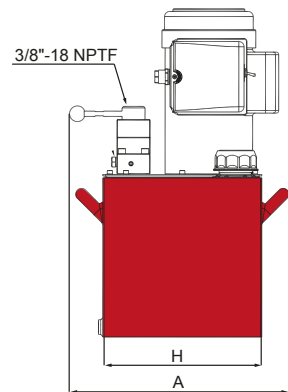
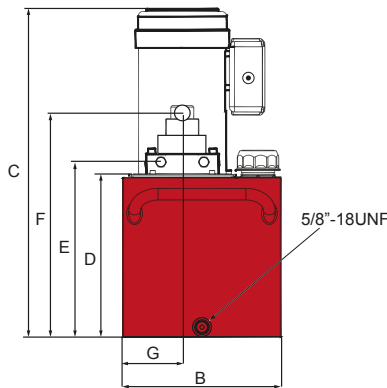

PE40/PE50/PE60 Series

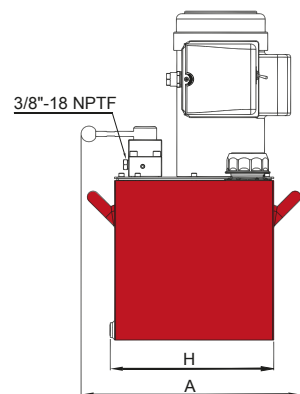
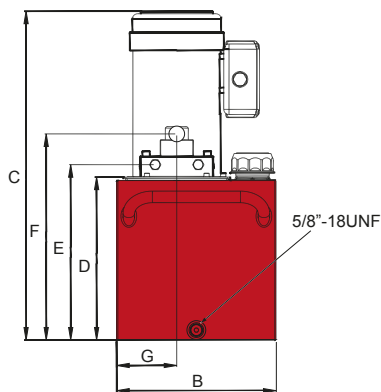

PE40/PE50/PE60 Series

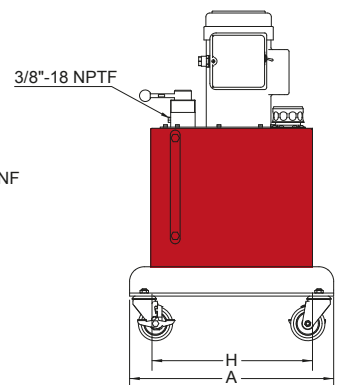
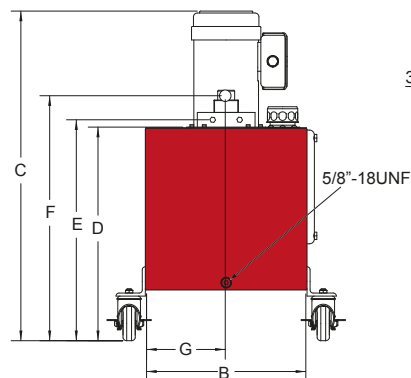

Pump Accessories
See the assortment of accessories designed to work with these pumps.
pg 62

80% Safety Practices
Good industry practice recommends not exceeding 80% of maximum rated capacities of all our products.

Safety Instructions
Visit our DO'S and DON'TS section to review the best methods of operation. Always be prepared.
pg 102

Pressure Settings
Custom pressure settings available upon request. Contact your local BVA dealer.

Reservoir Sizing
Recommended reservoir sizing is Extended Cylinder + Hose Volume Oil Capacity x 1.3

Will be delivered without Hydraulic Oil

Reservoir Size (L)	Dimensional Table (mm)								Pump Weight by Series* (kg)			
	A	B	C	D	E	F	G	H	PE30	PE40	PE50	PE60
3.8	419	301	485	119	145	305	206	315	30.5	-	-	-
7.6	421	321	455	152	175	335	114	315	32	35	-	-
11.4	421	325	502	183	208	267	114	315	34	36.7	41.3	-
19.4	421	325	654	312	335	394	114	315	-	39	41	47.3
60	531	419	879	561	587	645	211	419	-	64	70	76

* Pump weights include oil.

Single Phase Pump Matrix Chart

If you don't see a pump that would fit your application needs, you can custom build a pump to your desired specifications. Use this Pump Matrix Chart as a guide for creating your very own custom built Electric Pump. For assistance in building your pump, call your local BVA Representative.

P **E** **30** **S4U** **02** **A**

1	2	3	4	5	6
Product Type	Motor Type	Flow Group	Valve Type /Operation	Reservoir Size	Voltage

1 - Product Type

P Pump

2 - Motor Type

E Induction Electric Motor, TEFC

3 - Flow Group

30	4.2/0.24 L/min @ 25/700 BAR, ½ Hp (0.37 kW)
40	4.2/0.49 L/min @ 48/700 BAR, 1 Hp (0.75 kW)
50	6.4/0.83 L/min @ 48/700 BAR, 1.5 Hp (1.12 kW)
60	7.1/1.5 L/min @ 48/700 BAR, 3 Hp (2.24 kW)

4 - Valve Type/Operation

CURM Pump Mounted Manifold Block - Pressure & Return Ports Only

M2U Manual Valve 3W/2P
M3U Manual Valve 3W/3P
M4U Manual Valve 4W/3P
M3LU Manual Valve 3W/3P w/Locking Plate
M4LU Manual Valve 4W/3P w/Locking Plate

W2U Manual Valve 3W/2P w/3 meter Motor Control Pendant
W3U Manual Valve 3W/3P w/3 meter Motor Control Pendant
W4U Manual Valve 4W/3P w/3 meter Motor Control Pendant
W3LU Manual Valve 3W/3P w/Locking Plate and 3 meter Motor Control Pendant
W4LU Manual Valve 4W/3P w/Locking Plate and 3 meter Motor Control Pendant

S3U Solenoid Valve 3W/3P (Spool Type)
S4U Solenoid Valve 4W/3P (Spool Type)

5 - Reservoir Size

01	1 Gallon / 3.8 L
02	2 Gallons / 7.6 L
03	3 Gallons / 11.4 L
05	5 Gallons / 19.4 L
15	15 Gallons / 60 L (Including castors)

6 - Voltage

A 120V 1 ph 50 Hz
D 230V 1 ph 50 Hz - European Plug



PE Series

Ordering Example

PE30M4N01D

After reviewing this model number, we know that the pump has the following specifications:

- Electric power source
- ½ Hp (0.37 kW) flow group
- Manual Valve 4W/3P
- 1 gallon/3.8 L reservoir tank



PE30M4U01D



Related Product: Gauges

Reduce the risk of overloading your product by using a gauge. A variety of graduations and types to suit any need.

pg 71



Related Product: Footpedals

These can be used with all pumps equipped with solenoid valves

pg 66



Related Product: Hoses

We offer a variety of hoses, fittings, lengths and materials.

pg 73



Safety Instructions

Visit our DO'S and DON'TS section to review the best methods of operation. Always be prepared.

pg 102



Will be delivered without Hydraulic Oil

Not all options are available in all configurations. Table is for reference only. Please consult your local BVA dealer if you want to order a custom pump or if you have questions.

Manual Pumps

Air Pumps

Rotary Air pumps

Electric Pumps

Torc wrench pump

3 Phase Pump

Gas/ Diesel Pumps

Pump & Cylinder sets

1500 BAR



Torc wrench pump

- Torq 1 or up to 4 separate wrenches simultaneously.
- With integrated manometer.
- Pendant operated.
- Rollcage optional.
- Optional heat exchanger / system filter.



PU55T4W025C

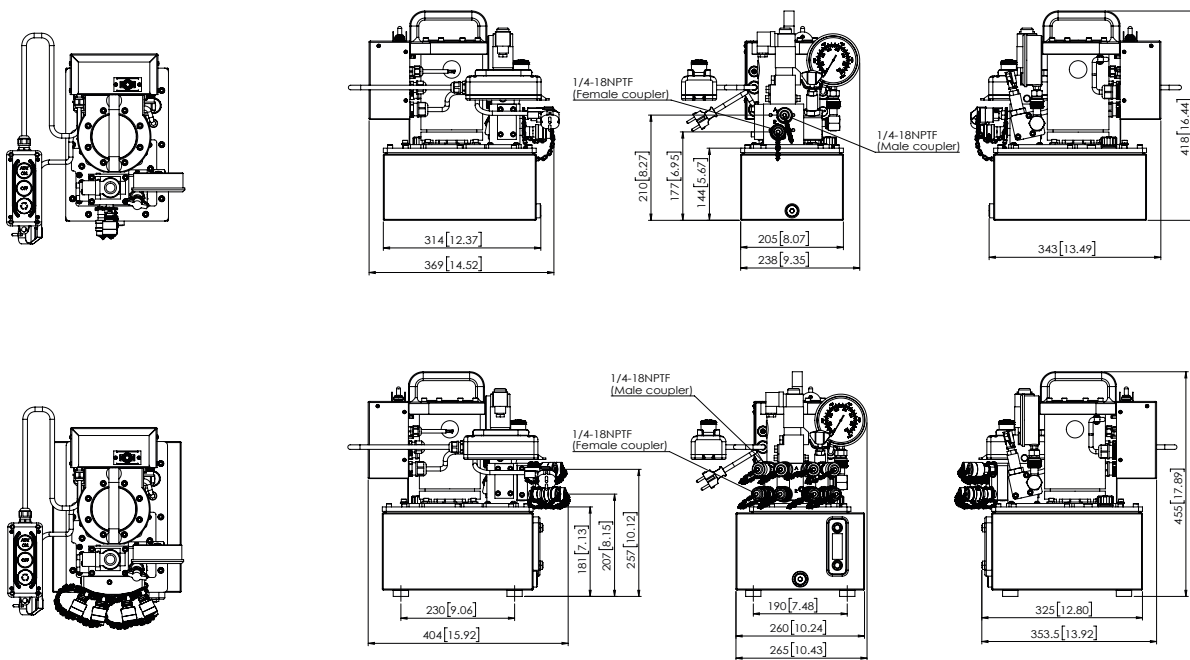

Model Number	Usable Oil Capacity (Liter)	Output Flow Rate (L / Min)			Motor Voltage	Pump Dimension	Current Draw @10,000 PSI (Amp)	Noise Level (dBA)	Weight (w/Oil, kg.)
		48 BAR	450 BAR	700 BAR					
PU55T1W025B	9,4	7,2	1,3	1,1	120VAC, 50/60HZ	350 mm (Length)	23	90	32,1
PU55T1W025C	9,4	7,2	1,2	1	240VAC, 50/60HZ	265 mm (Width)	11	90	31,7
PU55T4W025B	9,4	7,2	1,3	1,1	120VAC, 50/60HZ	455 mm (Height)	23	90	34,4
PU55T4W025C	9,4	7,2	1,2	1	240VAC, 50/60HZ		11	90	34

3-Phase Electric Pumps

380V Electric power



PE60M4U06W

- All hand pendants are wired with 24 VAC.
- Quiet operation meets OSHA regulations (80dBA).
- 2 speed operation allows for faster cylinder advance.
- Full load starting capacities.
- Internal suction strainer keeps contamination from damaging pump.
- Rugged durable design meets the demands of industrial applications.
- Precision components to minimize wear and improve overall dependability.
- Reservoirs equipped with sight level gauges.
- PE60 Models are standard as 380 VAC 50 Hz.

3-Phase Pump Matrix Chart

If you don't see a pump that would fit your application needs, you can custom build a pump to your desired specifications. Use this Pump Matrix Chart as a guide for creating your very own custom built Electric Pump. For assistance in building your pump, call your local BVA Representative.

P	E	60	M4U	06	W
1	2	3	4	5	6
Product Type	Motor Type	Flow Group	Valve Type /Operation	Reservoir Size	Voltage

1 - Product Type

P Pump

2 - Motor Type

E Induction Electric Motor, TEFC

3 - Flow Group

60 6300 cc/min @ 48 BAR
1330 cc/min @ 700 BAR, 3.0 Hp

4 - Valve Type/Operation

CURM Pump Mounted Manifold Block - Pressure & Return Ports Only
M2U Manual Valve 3W/2P
M3U Manual Valve 3W/3P
M4U Manual Valve 4W/3P
W3U Manual Valve 3W/3P w. 3 meter Motor Control Pendant
W4U Manual Valve 4W/3P w. 3 meter Motor Control Pendant
S4U Solenoid Valve 4W/3P (Spool Type)

5 - Reservoir Size

06 6 Gallons / 22.7 L

6 - Voltage

W 380-415V 3 ph 50 Hz



Safety Instructions

Visit our DO'S and DON'TS section to review the best methods of operation. Always be prepared.

102 pg

Pressure Settings
 Custom pressure settings available upon request. Contact your local BVA dealer.

Safety Practices
 Good industry practice recommends not exceeding 80% of maximum rated capacities of all our products.

Will be delivered without Hydraulic Oil

Pump Accessories
 See the assortment of accessories designed to work with these pumps.

Related Product: Gauges
 Reduce the risk of overloading your product by using a gauge. A variety of graduations and types to suit any need.

Related Product: Hoses
 We offer a variety of hoses, fittings, lengths and materials.

Model Number	Valve Type	Valve Function	Motor Voltage (volts)	Sound Level (dBA)	Motor Size (kW)	Usable Oil Capacity (L)	Pressure Rating (BAR)		Oil Output Flow Rate (L)		Current Draw (Amp)
							1 st Stage	2 nd Stage	1 st Stage	2 nd Stage	
380 Volt											
PE60M4U06W	Manual	4-Way 3-Position	380	80	2.24	22.7	48	700	6.3	1.33	4.5
PE60S4N06W	Solenoid	4-Way 3-Position	380	80	2.24	22.7	48	700	6.3	1.33	4.5

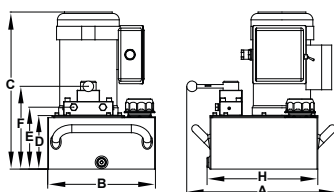

Model Number	Dimensions (mm)							Weight (kg)
	A	B	C	D	E	F	H	
380 Volt								
PE60M4U06W	524	376	583	224	247	307	436	62
PE60S4N02W	524	376	583	224	247	307	436	62



Gas and Diesel Pumps

PG/PD Series - Portable Power



PG70M4U05



PD70M4U05



Will be delivered without Hydraulic Oil

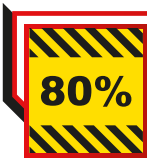

Safety Practices

Good industry practice recommends not exceeding 80% of maximum rated capacities of all our products.



Related Product: Gauges

Reduce the risk of overloading your product by using a gauge. A variety of graduations and types to suit any need.

71 pg



Related Product: Hoses

We offer a variety of hoses, fittings, lengths and materials.

73 pg



Safety Instructions

Visit our DO'S and DON'TS section to review the best methods of operation. Always be prepared.

102 pg

Gas Pumps



- Gas engine pumps will provide 10,000 psi at remote locations
- Industrial grade 5.5 Honda Gas Engine
- Ideal for applications at remote locations
- Two speed pump designed for rapid cylinder advance
- Gas pump features a sturdy protective roll cage for use in the toughest environments
- Manual control valve for use with single or double acting cylinders or tools

Diesel Pumps



- Diesel engine pumps will provide 10,000 psi at remote locations
- Industrial grade 4.6 hp / 3.5 kN HATZ Diesel engine
- Locking solenoid control valve for use with single or double acting cylinders or tools
- Two speed pump designed for rapid cylinder advance
- Pump features a sturdy protective roll cage for use in the toughest environments
- Ideal for application when diesel fuel in remote environments is required
- Optional: electric start

Valve Function	Valve Type		7.4 Gal / 19.4 L	Flow Rate			
				1 st Stage		2 nd Stage	
				Model Number		L/min	BAR
3W/3P Advance/Hold Return	Manual	7.4 Gal Gas - 5.5 Hp Honda	PG70M3U05	7.0	48.3	1.6	700
	Solenoid (only for Diesel)	12.2 Gal Diesel - 4.6 Hp HATZ	PD70M3U05	9.8	48.3	3.3	700
4W/3P Advance/Hold Return	Manual	7.4 Gal Gas - 5.5 Hp Honda	PG70M4U05	7.0	48.3	1.6	700
	Solenoid (only for Diesel)	12.2 Gal Diesel - 4.6 Hp HATZ	PD70M4U05	9.8	48.3	3.3	700

Gas and Diesel Pumps

PG/PD Series



PG70M3U05

PD70M4U05

Safety Practices
Good industry practice recommends not exceeding 80% of maximum rated capacities of all our products.

Related Product: Gauges
Reduce the risk of overloading your product by using a gauge. A variety of graduations and types to suit any need.

pg 71

Related Product: Hoses
We offer a variety of hoses, fittings, lengths and materials.

pg 73

Safety Instructions
Visit our DO'S and DON'TS section to review the best methods of operation. Always be prepared.

pg 102

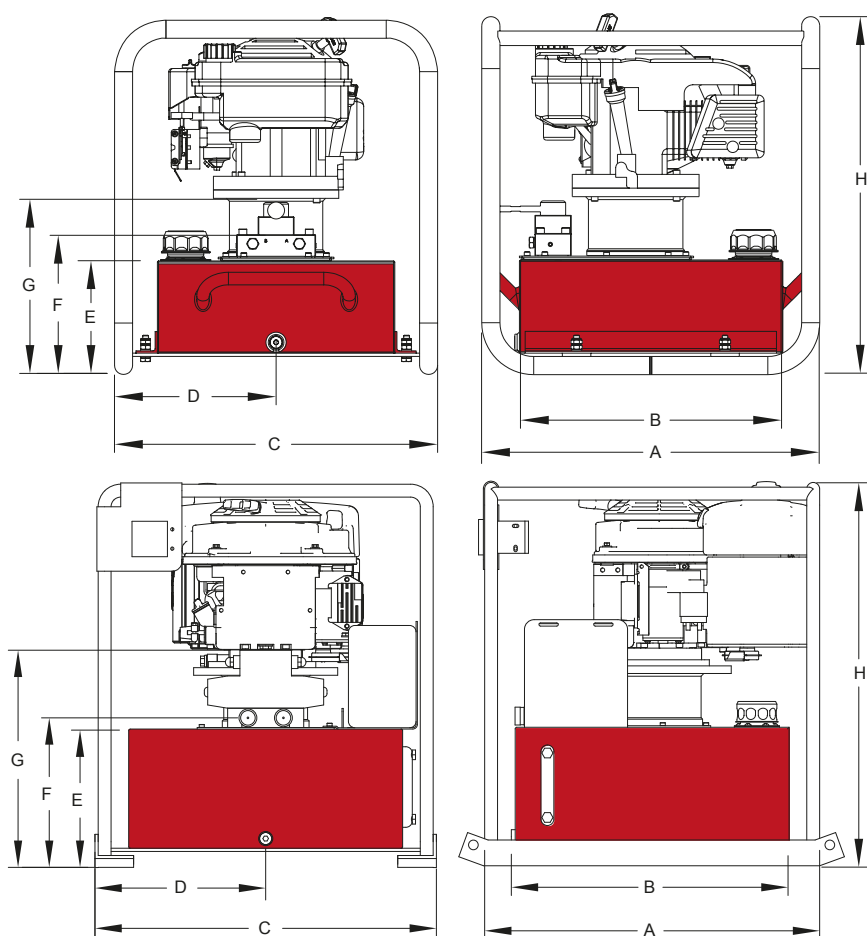

Model Number*	Dimensions (mm)						Weight** (Kg)
	A	B	C	D	E	H	
Gas Pumps							
PG70xxx05	952	469	572	286	208	627	73.5
Diesel Pumps							
PD70xxx10	830	593	686	343	304	828	149.2

* "xxx" in the model number refers to the type of valve you may use on the gas/diesel engine pump. Refer to your local BVA dealer or the Matrix Chart (on page 58) to build your own pump.
** Pump weights include oil.

- Manual Pumps
- Air Pumps
- Rotary Air pumps
- Electric Pumps
- Torc wrench pump
- 3 Phase Pump
- Gas/ Diesel Pumps**
- Pump & Cylinder sets
- 1500 BAR



Combinations

Pump and Cylinder Sets

Each set includes:

- 1/4" ID 2 meter Hydraulic Hose.
- 3/8" High Flow Male Coupler.
- 63 mm Diameter Wet Gauge.



Single Acting Cylinder Type	Cylinder				Hand Pump P352	Hand Pump P1000	Hand Pump P2301	Air Pump PA1500
	Capacity	Model Number	Stroke (mm)	Collapsed Height (mm)				
General Purpose Cylinders 	5 Tonne 44 kN	H0505	129	221	SP352-0505	-	-	-
	10 Tonne 99 kN	H1002	51	123	-	SP10-1002	-	SA15-1002
		H1004	102	174	-	SP10-1004	-	SA15-1004
		H1006	155	250	-	SP10-1006	-	SA15-1006
		HT1006	151	291	-	SP10-1006T	-	SA15-1006T
		H1010	257	352	-	SP10-1010	-	SA15-1010
		HT1010	253	393	-	SP10-1010T	-	SA15-1010T
	15 Tonne 139 kN	H1504	101	200	-	SP10-1504	-	SA15-1504
		H1506	152	270	-	SP10-1506	-	SA15-1506
	25 Tonne 228 kN	H2502	51	168	-	SP10-2502	-	SA15-2502
		H2504	102	219	-	SP10-2504	-	SA15-2504
		H2506	155	272	-	SP10-2506	-	SA15-2506
		H2508	206	323	-	-	SP23-2508	SA15-2508
		H2514	362	476	-	-	SP23-2514	SA15-2514
	50 Tonne 487 kN	H5506	159	283	-	-	SP23-5506	SA15-5506
100 Tonne 911 kN	H10002	51	219	-	-	SP23-10002	-	
Flat Body Cylinders 	5 Tonne 49 kN	HF0503*	6	32	SP352-0503F	-	-	-
		HF0503B *	6	32	SP352-0503B	-	-	-
	10 Tonne 104 kN	HF1005	11	43	SP352-1005F	-	-	-
		HF1005B	11	43	SP352-1005B	-	-	-
	20 Tonne 194 kN	HF2005	11	51	SP352-2005F	-	-	-
		HF2005B	11	51	SP352-2005B	-	-	-
	30 Tonne 288 kN	HF3005	13	59	SP352-3005F	-	-	-
		HF3005B	13	59	SP352-3005B	-	-	-
	45 Tonne 437 kN	HF5006	16	67	SP352-5006F	-	-	-
		HF5006B	16	67	SP352-5006B	-	-	-
	75 Tonne 726 kN	HF7506	16	80	SP352-7506F	-	-	-
90 Tonne 870 kN	HF10006	16	86	SP352-10006F	-	-	-	
150 Tonne 1359 kN	HF15006	16	100	-	SP10-15006F	-	-	

* Fitted with CR38F coupler



We see here our combo kit SA15-3002L getting set up to lift a load. This combo kit includes a HL3002 cylinder, PA1500 air pump, CS3814 hose, CH38M coupler set, CF3814 gauge adapter and a GBW1460 pressure gauge.

Combinations

Pump and Cylinder Sets



Single Acting Cylinder Type	Cylinder				Hand Pump P352	Hand Pump P1000	Hand Pump P2301	Air Pump PA1500
	Capacity	Model	Stroke (mm)	Collapsed Height (mm)				
Hollow Hole Cylinders 	12 Tonne 129 kN	HC1201T	8	60	SP352-1201T	-	-	-
		HC1202	41	121	SP352-1202T	-	-	-
		HC1202XT	41	121	SP352-1202XT	-	-	-
		HC1203XT	76	184	-	SP10-1203XT	-	-
	20 Tonne 217 kN	HC2002T	51	162	-	SP10-2002T	-	SA15-2002T
	30 Tonne 280 kN	HC3002T	64	179	-	SP10-3002T	-	SA15-3002T
		HC3006T	155	331	-	SP10-3006T	-	SA15-3006T
	60 Tonne 578 kN	HC6003T	76	248	-	SP10-6003T	-	SA15-6003T
HC6006T		152	324	-	-	SP23-6006T	SA15-6006T	
100 Tonne 980 kN	HC10003T	76	254	-	-	SP23-10003T	SA15-10003T	
Low Profile Cylinders 	10 Tonne 104 kN	HL1001	38	89	SP352-1001L	SP10-1001L	-	SA15-1001L
	10 Tonne 104 kN	HL1001D	38	89	SP352-1001LD	SP10-1001LD	-	SA15-1001LD
	20 Tonne 194 kN	HL2002	44	99	SP352-2002L	SP10-2002L	-	SA15-2002L
	30 Tonne 288 kN	HL3002	62	117	SP352-3002L	SP10-3002L	-	SA15-3002L
	45 Tonne 437 kN	HL5002	60	122	-	SP10-5002L	-	SA15-5002L
	90 Tonne 870 kN	HL10002	57	141	-	SP10-10002L	SP23-10002L	SA15-10002L
Lock Nut Cylinders 	50 Tonne 487 kN	HLN5502	50	165	-	-	SP23-5502LN	SA15-5502LN
		HLN5504	100	213	-	-	SP23-5504LN	SA15-5504LN
		HLN5506	150	264	-	-	SP23-5506LN	SA15-5506LN
Aluminum Cylinders 	30 Tonne 303 kN	HU3002T	50	181	SP352-3002U	-	-	SA15-3002U
		HU3006T	150	281	-	SP10-3006U	-	SA15-3006U
	50 Tonne 487 kN	HU5506T	150	286	-	-	SP23-5006U	SA15-5006U

Manual Pumps

Air Pumps

Rotary Air pumps

Electric Pumps

Torc wrench pump

3 Phase Pump

Gas/ Diesel Pumps

Pump & Cylinder sets

1500 BAR



1500 BAR Bolt tensioner

Pump and Cylinder Sets

- Fiveload cells from M16 to M105 or from 5/8"-11UN to 3 1/4"-8UN
- Twin ports for quick connection of multiple tools
- Only one size of bridge per size of load cell
- Detachable and rotational bridge simplifies tool positioning
- Full bridge window - increased access to socket
- Piston stroke indicator
- Black surface treatment protects against corrosion
- Anti-slip grip for more secure handling
- Universal and multi-use tool
- GT-Series Tensioners comply to Machine Directive 2006/42/CE

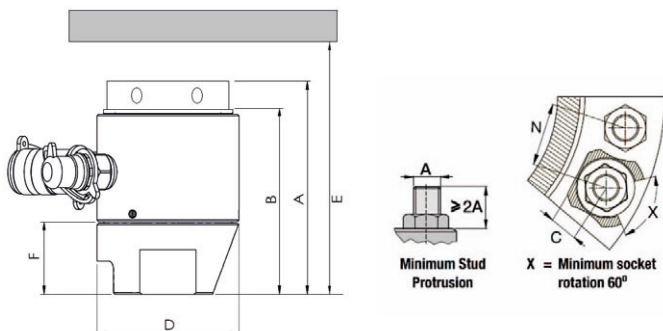

Adaptor Kit Model Number	Thread Size	Bridge Model Number / Cylinder Effective area (mm ²) / Max load capacity (kN)	Dimensions (mm)								Load Cell and Bridge Weight	Weight** (Kg)
			A	B	C	D	E	F	N			
TB401 Hydraulic Topside Bolt Tensioner M16~M30												
TB401-01620	M16 x 2	TB401 1508 mm ² 226,2 kN	135	113	27	86	243	44	57	3,4	1,7	
TB401-01825	M18 x 2.5		135	113	27	86	243	44	58	3,4	1,6	
TB401-02025	M20 x 2.5		135	113	27	86	243	44	59	3,4	1,5	
TB401-02430	M24 x 3		135	113	27	86	243	44	61	3,4	1,4	
TB401-02730	M27 x 3		135	113	27	86	243	44	64	3,4	1,3	
TB401-03035	M30 x 3.5		135	113	27	86	243	44	66	3,4	1,2	
TB401-0625U11	5/8" 11UN		135	113	27	86	243	44	57	3,4	1,7	
TB401-0750U10	5/8" 11UN		135	113	27	86	243	44	59	3,4	1,5	
TB401-0875U09	7/8" 9UN		135	113	27	86	243	44	62	3,4	1,4	
TB401-1000U08	1" 8UN		135	113	27	86	243	44	64	3,4	1,3	
TB401-1125U08	1-1/8" 8UN	135	113	27	86	243	44	66	3,4	1,1		
TB402 Hydraulic Topside Bolt Tensioner M30 ~ M39												
TB402-03035	M30 x 3.5	TB402 2889 mm ² 433,35 kN	136	111	35	107	226	41	75	4,7	2,7	
TB402-03335	M33 x 3.5		136	111	35	107	226	41	76	4,7	2,5	
TB402-03640	M36 x 4		136	111	35	107	226	41	79	4,7	2,3	
TB402-03940	M39 x 4		136	111	35	107	226	41	82	4,7	2,0	
TB402-1125U08	1-1/8" 8UN		136	111	35	107	226	41	74	4,7	2,7	
TB402-1250U08	1-1/4" 8UN		136	111	35	107	226	41	76	4,7	2,5	
TB402-1375U08	1-3/8" 8UN		136	111	35	107	226	41	79	4,7	2,3	
TB402-1500U08	1-1/2" 8UN		136	111	35	107	226	41	82	4,7	2,1	
TB403 Hydraulic Topside Bolt Tensioner M39 ~ M52												
TB403-03940	M39 x 4	TB403 5035 mm ² 755,25 kN	160	126	46	138	256	56	96	8,1	5,8	
TB403-04245	M42 x 4.5		160	126	46	138	256	56	98	8,1	5,5	
TB403-04545	M45 x 4.5		160	126	46	138	256	56	101	8,1	5,1	
TB403-04850	M48 x 5		160	126	46	138	256	56	104	8,1	4,8	
TB403-05250	M52 x 5		160	126	46	138	256	56	107	8,1	4,3	
TB403-1500U08	1-1/2" 8UN		160	126	46	138	256	56	95	8,1	5,8	
TB403-1625U08	1-5/8" 8UN		160	126	46	138	256	56	98	8,1	5,4	
TB403-1750U08	1-3/4" 8UN		160	126	46	138	256	56	101	8,1	5,1	
TB403-1875U08	1-7/8" 8UN		160	126	46	138	256	56	104	8,1	4,7	
TB403-2000U08	2" 8UN		160	126	46	138	256	56	106	8,1	4,3	

Adaptor Kit Model Number	Thread Size	Bridge Model Number / Cylinder Effective area (mm) / Max load capacity (kN)	Dimensions (mm)								Load Cell and Bridge Weight	Weight** (Kg)
			A	B	C	D	E	F	N			
TB404 Hydraulic Topside Bolt Tensioner M52 ~ M68												
TB404-05250	M52 x 5	TB404 9627 mm ² 1444,05 kN	180	141	62	174	281	71	121	14,2	10,8	
TB404-05655	M56 x 5.5		180	141	62	174	281	71	124	14,2	10,2	
TB404-06055	M60 x 5.5		180	141	62	174	281	71	127	14,2	9,5	
TB404-06460	M64 x 6		180	141	62	174	281	71	129	14,2	8,9	
TB404-06860	M68 x 6		180	141	62	174	281	71	132	14,2	8,2	
TB404-2000U08	2" 8UN		180	141	62	174	281	71	120	14,2	10,8	
TB404-2250U08	2-1/4" 8UN		180	141	62	174	281	71	126	14,2	9,8	
TB404-2500U08	2-1/2" 8UN		180	141	62	174	281	71	132	14,2	8,6	
TB405 Hydraulic Topside Bolt Tensioner M68 ~ M80												
TB405-06860	M68 x 6	TB405 15186 mm ² 2277,9 kN	202	157	78	210	302	86	148	23,4	17,4	
TB405-07260	M72 x 6		202	157	78	210	302	86	149	23,4	16,5	
TB405-07660	M76 x 6		202	157	78	210	302	86	152	23,4	15,6	
TB405-08060	M80 x 6		202	157	78	210	302	86	155	23,4	14,7	
TB405-2500U08	2-1/2" 8UN		202	157	78	210	302	86	148	23,4	17,9	
TB405-2750U08	2-3/4" 8UN		202	157	78	210	302	86	153	23,4	16,4	
TB405-3000U08	3" 8UN		202	157	78	210	302	86	158	23,4	14,9	
TB405-3250U08	3-1/4" 8UN		202	157	78	210	302	86	161	23,4	13,2	

1500 Bar Handpump



P1020HP

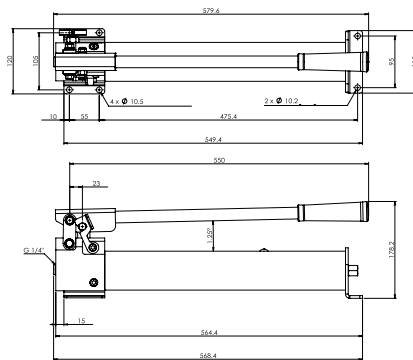
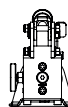

Model Number	Usable Oil Capacity (cc)	Oil Outlet Port	Pressure Rating/Oil Displacement per Stroke		Piston Stroke (mm)	Handle Operating Force (N)	Reservoir Construction	Weight (kg)
			A	B				
2-Speed - Single Acting								
P1020HP	1000	G 1/4"	20 / 15,3	1500 / 1,2	24	406	Aluminum	7,3

Couplers and hoses



Type	Model Number	Length (mm)	Connection	Max working pressure (Bar)	Min burst pressure (Bar)	Temperature range
Coupler Male	CQH14M	38,0	G 1/4" Female	1500	3000	-30°C / +100°C
Coupler Male	CQH14F	61,3	G 1/4" Female	1500	3000	-30°C / +100°C
Connector	CQH14-ADP	26,0	G 1/4" Male	1500	3000	-30°C / +100°C
Pressure washer	CQH14-WASHER	20,6	-	1500	3000	-30°C / +100°C
1500Bar Hose	CSH1414-XXX	1000~10000 (on request)	CQH14M/F (on request)	1500	3750	-10°C / +70°C



Flow Control Valves

700 BAR Rated



CVR3

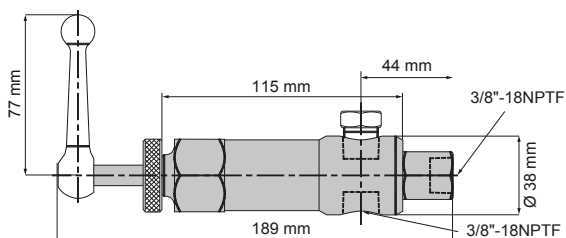

CVL3

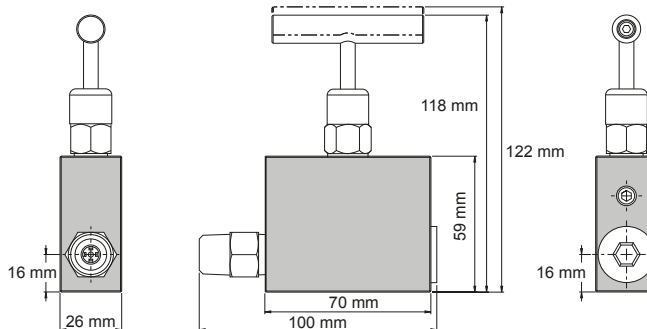

CVLS3

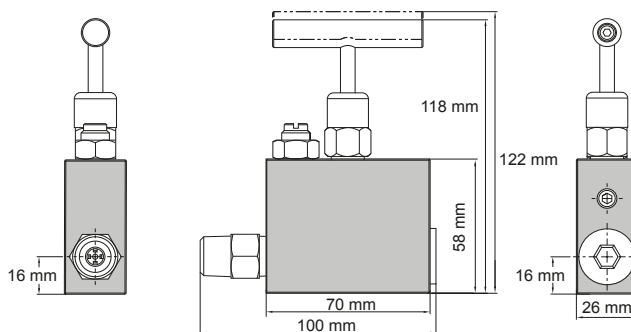

Valve Type	Model Number	Ports	Applications	Hydraulic Symbol
Pressure Relief Valve	CVR3	3/8"-18NPTF	Controls pressure developed by the pump in hydraulic loop. By-pass occurs when preset pressure reaches 0-10,000 PSI. Turn clockwise to increase pressure, counter-clockwise to decrease.	
	CVR3/H	3/8"-18NPTF	Same as CVR3, but return line hose / 1 meter length is included.	
Manual Operated Check Valve	CVL3	3/8"-18NPTF	Mounted in line with a cylinder and will hold pressure in the cylinder in the event of pressure loss in the system. Pressure is manually released.	
	CVLS3	3/8"-18NPTF	Mounted in line with a cylinder and will hold pressure in the cylinder in the event of pressure loss in the system. This model is equipped with high-pressure bypass. Pressure is manually released.	

Flow Control Valves

700 BAR Rated



CVN1 and CVN3

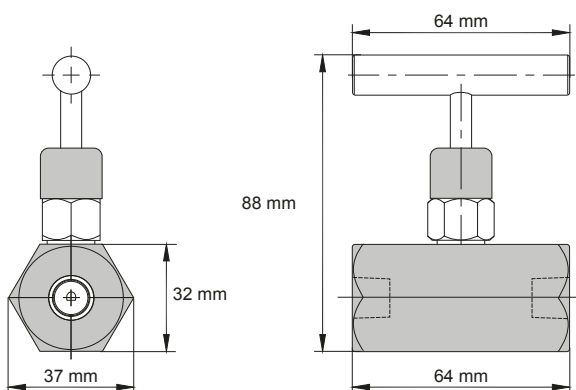

CVC3

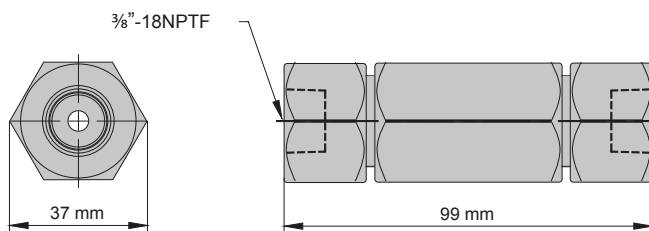

CVP3

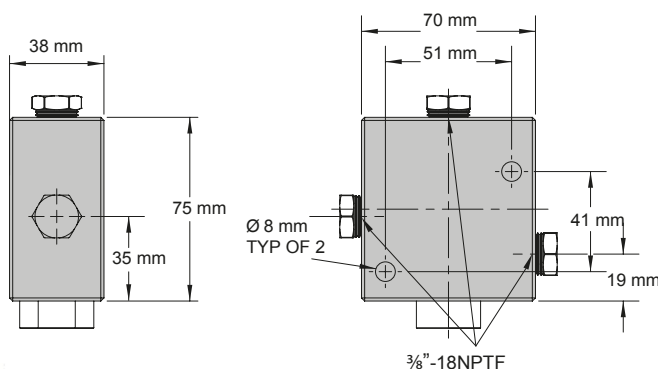

CVB

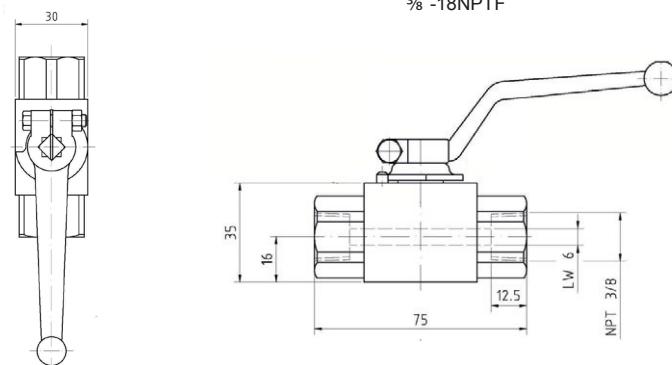

- Flow control valves
- Manifolds
- manometers adapters
- Hydraulic oil
- Pressure adjustment
- Foot pedal
- Couplers
- Hoses
- Valves
- Fittings

Valve Type	Model Number	Ports	Applications	Hydraulic Symbol
Needle Valve	CVN1	1/4"-18NPTF	Controls cylinder speed and acts as temporary shut-off valve for load holding.	
	CVN3	3/8"-18NPTF		
Check Valve	CVC3	3/8"-18NPTF	Allows flow in one direction only.	
Pilot Operated Check Valve	CVP3	3/8"-18NPTF	Mounted in line with a cylinder which will hold pressure in the event of pressure loss in the system. Most often used on double-acting cylinders with pilot port, receiving pressure from a tee off of the cylinder retracting line. Pilot pressure ratio 15% or 6.5:1	
Ball valve holding	CVB	3/8"-18NPT	Temporary shut off valve for load	



Manifolds

700 BAR Rated



CMH6

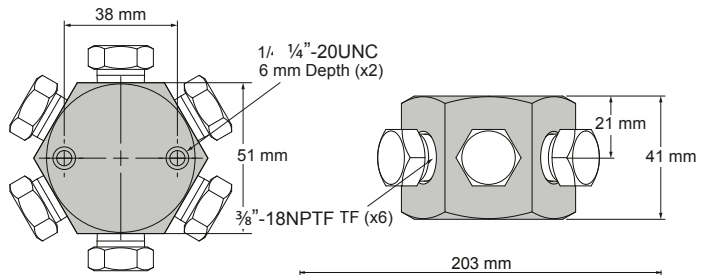

CM7

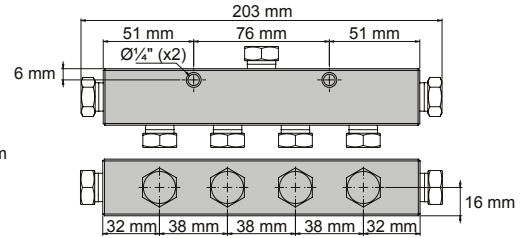
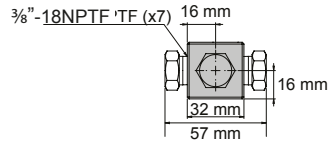

CM14

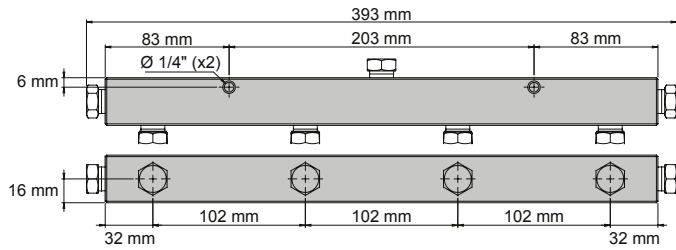

MFC2

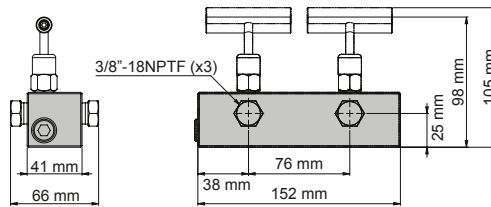
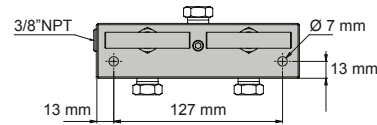

MFC4

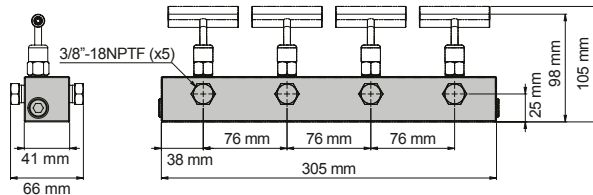
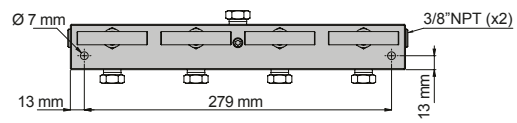

Manifold Type	Model Number	Number of Ports	Port Size	Mounting Holes
6-Port Hexagon Manifold	CMH6	6	3/8"-18NPTF	1/4"-20UNC
7" Long Manifold	CM7	7	3/8"-18NPTF	1/4"-20UNC
14" Long Manifold	CM14	7	3/8"-18NPTF	1/4"-20UNC
Manifold with Two Needle Valves	MFC2	2	3/8"-18NPTF	7mm Dia.
Manifold with Four Needle Valves	MFC4	4	3/8"-18NPTF	7mm Dia.

Hydraulic Pressure Gauge



Model Number	Face Dia. (mm)	Thread (in)	Material	Pressure Range		Graduation			
				(psi)	(bar)	Major Graduation (psi)	Minor Graduation (psi)	Major Graduation (bar)	Minor Graduation (bar)
GBW1460	63	1/4"-18 NPTF	Brass	0-14500	0-1000	1000	500	100	20
GBW12100	105	1/2"-18 NPTF	Brass	0-15000	0-1000	1000	500	100	20
GSW1460	63	1/4"-18 NPTF	Stainless	0-10000	0-700	1000	500	100	20
GD1480	80	1/4"-18 NPTF	Stainless	0-10000	0-700	-	-	-	-

Gauge Adapter

700 BAR Rated

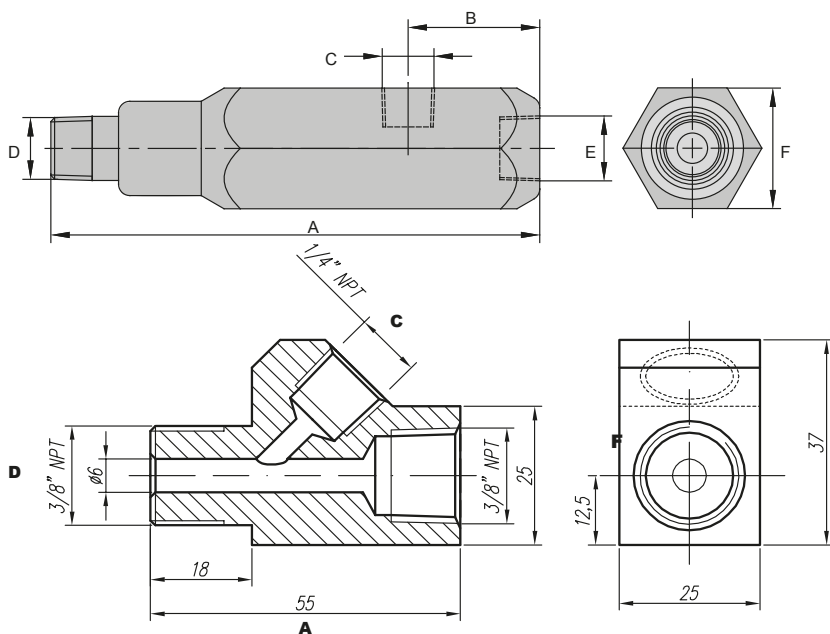

Model Number	Dimensions (mm)					
	A	B	C	D	E	F
CF3814	130	35	1/4"-18 NPTF	3/8"-18 NPTF	3/8"-18 NPTF	32
CF3814-45	55	-	1/4"-18 NPT	3/8"-18 NPT	3/8"-18 NPT	25
CF3814-45L	82	-	1/4"-18 NPTF	3/8"-18 NPT	3/8"-18 NPT	25
CF3812 (E)	155	35	1/2"-14 NPTF	3/8"-18 NPT	3/8"-18 NPT	32
CF1414 (E)	71	25	1/4"-18 NPTF	1/4"-18 NPTF	1/4"-18 NPTF	23

Flow control valves

Manifolds

manometers adapters

Hydraulic oil

Pressure adjustment

Foot pedal

Couplers

Hoses

Valves

Fittings



Hydraulic Oil

- Recommended for all BVA cylinders and pumps

Volume (L)	Model Number	Viscosity Index	Viscosity @ 40°C (mm ² /S)	Viscosity @ 100°C (mm ² /S)	Viscosity Grade, ISO	Flash Point (°C)	Pour Point (°C)
5	HV155	159	15	3.89	15	160	-57
5	HV465	x	46	x	46	x	x
5	HV685	152	68	11	68	230	-42



HV155

HV685

* adv. HV685 for electric pump, HV155 for air / hand pump.

External Pressure Adjustment

Sandwich Mounted

Model Number	Pressure Adj. Range (BAR)	Interval (BAR)	Suitable Model
PW-AS1	70	3.5	PE Series, 3.8 L. Reservoir
PW-AS2	~ 700		PE Series, 7.6 L (+). Reservoir
PW-AS3			PU20 Series Pump



PW-AS1

- Pressure can be adjusted externally (70-700 bar)
- Works with single and double acting cylinders

Pressure Switch

CVS1

- Automatically shuts off electric pump when predetermined system pressure is reached

Model Number	Adjustable Pressure Range	Electrical Rating	Port Size	Weight (kg)
CVS1	69~700.35 BAR	15 amp @ 250V max	¼"-18NPTF	0.6

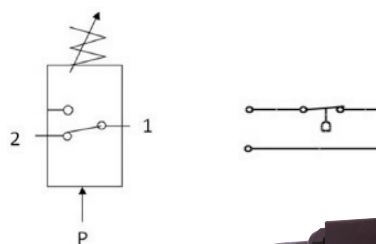

CVS1



FP1

FP2

Foot Pedals

Single or Double

- Hands free pump operation
- Can be used with all pumps equipped with solenoid valves

*FP1 for standard electric pumps on/off
FP2 for solenoid pumps push/pull*

*Foot controls with 3 meter cord.
(This option replaces the hand controls on solenoid equipped models.)*



CDC38

Coupler Dust Cover

- Keeps contaminants out of the system

Model Number	Coupler Compatibility
CDC38	CH38, CH38F, CH38M

Hydraulic Couplers

10,000 PSI Rated

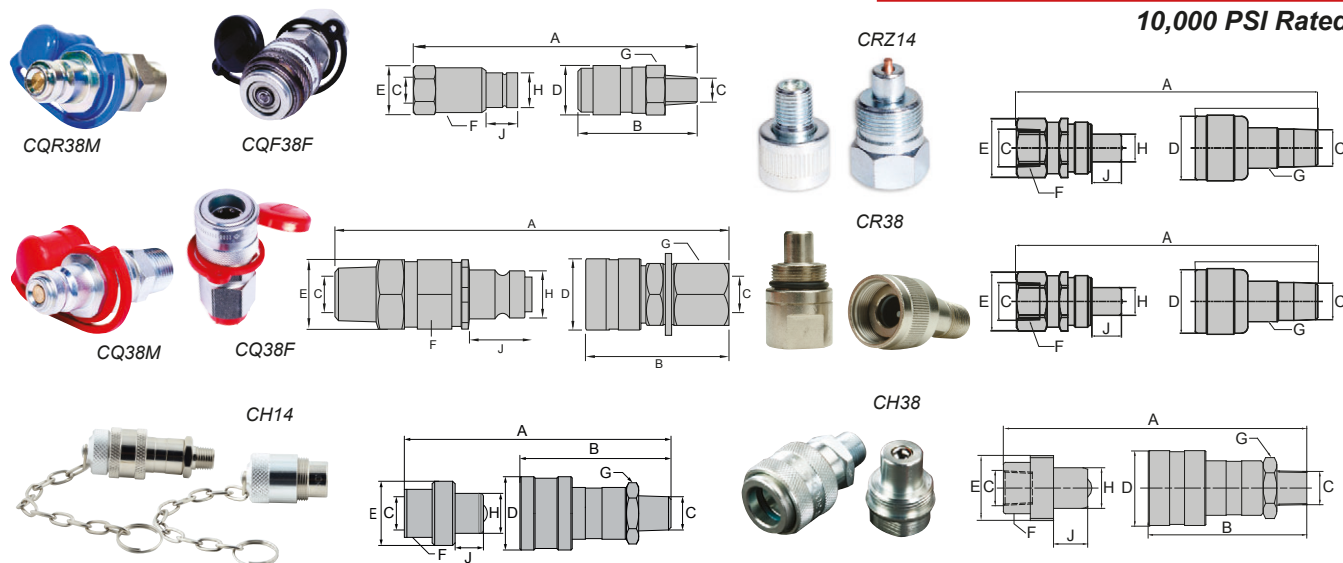

Max Flow Capacity (l/min)	Coupler Type	Model Numbers			Dimensions (mm)								
		Complete Set	Male Half	Female Half	A*	B	C	D	E	F	G	H	J
35	High-Flow Coupler	CH38	CH38M	CH38F	86	72	3/8"-18NPTF	35	30	19	25.4	19	16
10	Regular-Flow Coupler	CR38	CR38M	CR38F	80	56	3/8"-18NPTF	30	27	19	19	12.6	13.5
8	High-Flow Coupler	CH14	CH14M	CH14F	72	60	1/4"-18NPTF	29	25	19	21	15.8	11.4
6	Quick Connection	CQ38	CQ38M	CQ38F	105	61	3/8"-18NPTF	28	25	22	24	15.6	20
6	Hose Rupture Nipple	-	CQR38M	-	116	-	3/8"-18NPTF	-	25	22	-	15.6	20
5.3	Flat Face Coupler	-	-	CQF38F	116	71	3/8"-18NPTF	30	-	-	24	-	-
	Regular-Flow Coupler	CRZ14	CRZ14M	CRZ14F	61	43.5	1/4"-18NPTF	20.5	21	38.1	15	10	9

* Value A is total length when male and female couplers are connected.

Hydraulic Hoses

Hose Exceeds DIN 20022-1 & SAE 100R9 Specifications

- Rubber Bend Restrictors.
- High Working Pressure.
- Optimum Flexibility.
- Light Weight.
- Temperature Range: from -40°C up to +100 °C.

Polyamide
Aramid
Polyurethane
Stahldraht - Steenwire
Polyurethane



Model Number	Length (cm)	I.D. Ø	Hose End Fittings	Operating Pressure (BAR)	Bursting Pressure (BAR)	Bend Radius (mm)	Oil Volume (cc)	Weight (kg)
CS3814-1	100	6.35mm / 1/4"	3/8" - 18NPTF	700	2800	50	34	0.5
CS3814-2	200	6.35mm / 1/4"	3/8" - 18NPTF	700	2800	50	67	0.8
CS3814-3	300	6.35mm / 1/4"	3/8" - 18NPTF	700	2800	50	100	1.1
CS3814-4	400	6.35mm / 1/4"	3/8" - 18NPTF	700	2800	50	133	1.3
CS3814-6	600	6.35mm / 1/4"	3/8" - 18NPTF	700	2800	50	200	1.9
CS3814-10	1000	6.35mm / 1/4"	3/8" - 18NPTF	700	2800	50	332	3
CS3838-2	200	9.5mm / 3/8"	3/8" - 18NPTF	700	2800	150	158	0.8

* Available in other lengths on request



Solenoid Valves

Pump Mounted

- Pump mounted solenoid kits convert your manual pump to an electrically controlled pump.



Use With Cylinder	Model Number	Valve Type	Valve Function	Hydraulic Symbol	Schematic Flow path			Weight (kg)
Single Acting	PWS3	Solenoid 196 VDC	Advance/ Hold/ Return					3.4
Double Acting	PWS4	Solenoid 196 VDC	Advance/ Hold/ Return					3.9

Pressure Control Valve

PPC-1/PPC-2

- Modular valve with one or two cartridges.
- Excellent pressure adjustment over the entire operating range.
- PPC-1 and PPC-2 are only compatible with Solenoid Valves
- The extended mounting screws are not included



PPC-2

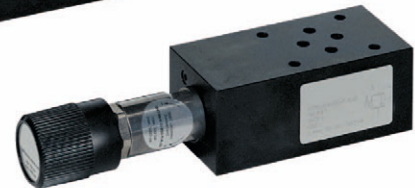

PPC-1



PFC

Valve	Model Number	Hydraulic Symbol
Pressure Control Valve	PPC-1 PPC-2	
Flow Control Valve	PFC	

Flow Control Valve

PFC

- Throttle check valves

Pump Mounted Manifold Block

CMRU2

- Converts BVA pumps with mounted valves for use with remote mounted valves
- 4 mounting bolts



CMRU2

Remote Mounted Directional Control Valves

Not to be used with Hand Pumps

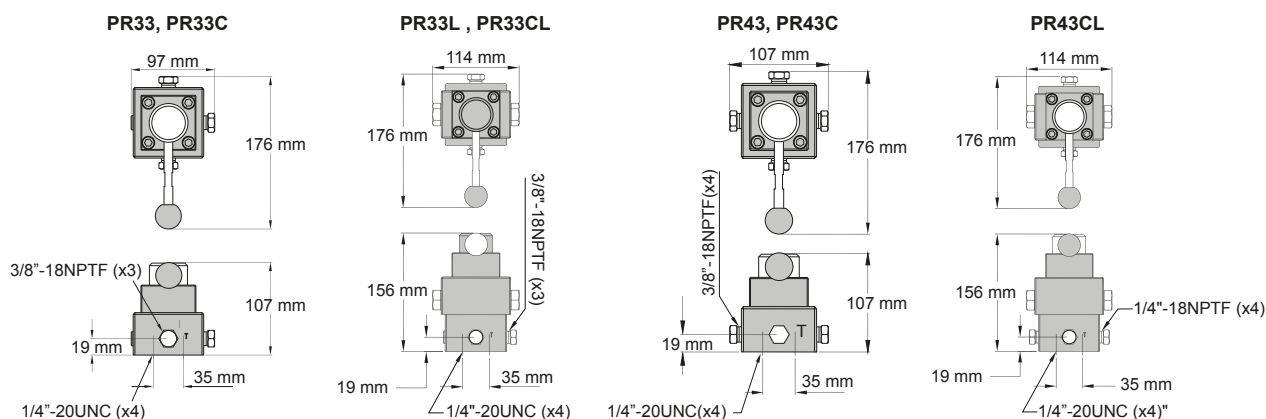

Valve Operation	Valve Type	Use w/ Cylinder	Model Number	Hydraulic Symbol	Schematic Flow path			Weight (kg)
Manual	3-Way, 3 Position, Tandem center	Single Acting	PR33					1.59
	3-Way, 3 Position, Closed center		PR33C					1.59
	3-Way, 3 Position, Tandem center, Locking		PR33L					2.59
	3-Way, 3 Position, Closed center, Locking		PR33CL					2.59
	4-Way, 3 Position, Tandem center	Double Acting	PR43					1.59
	4-Way, 3 Position, Tandem center, Locking		PR43L					2.59
	4-Way, 3 Position, Closed center		PR43C					1.59
4-Way, 3 Position, Closed center, Locking	PR43CL						2.59	

All valves have a detent in the center position.



Flow control valves

Manifolds

manometers adapters

Hydraulic oil

Pressure adjustment

Foot pedal

Couplers

Hoses

Valves

Fittings



Pump Mounted Valves



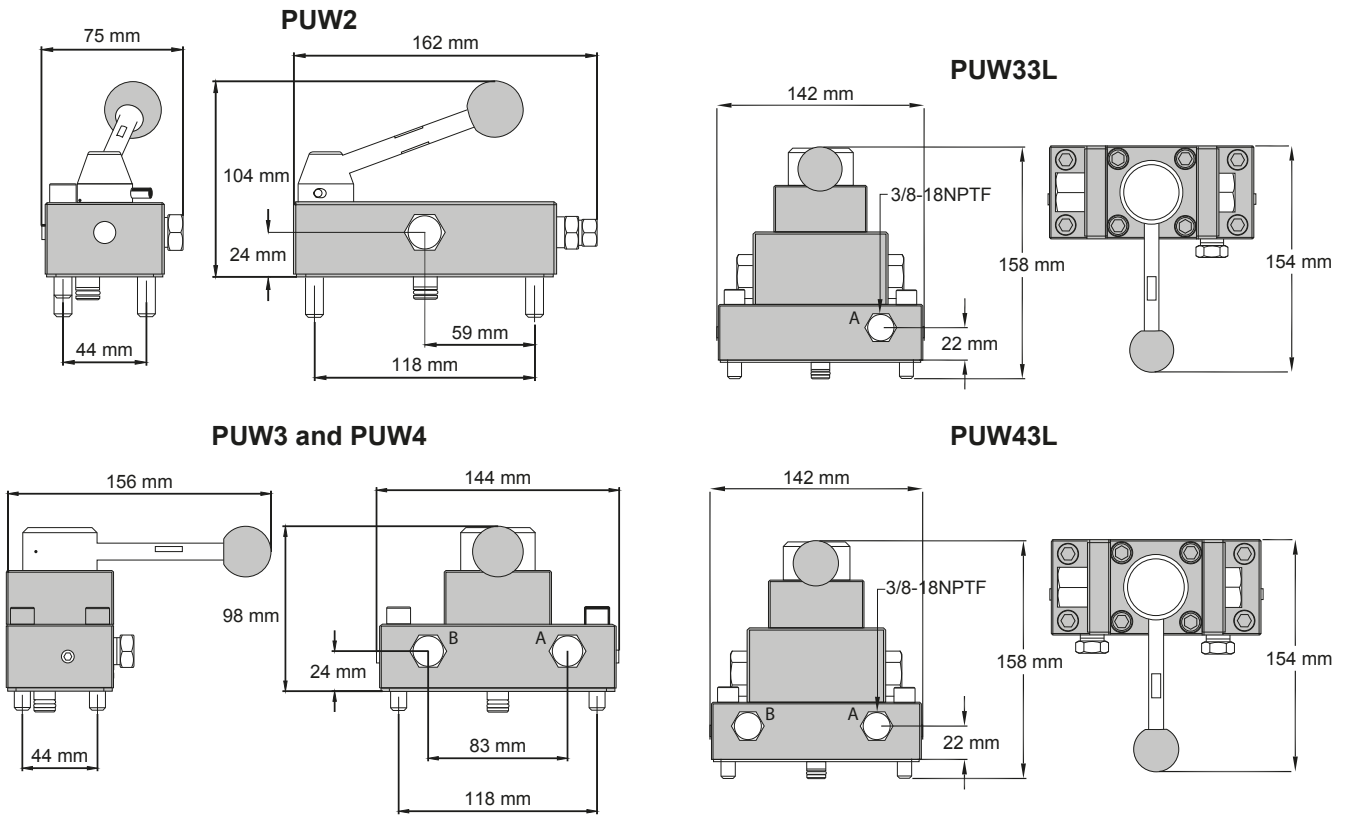







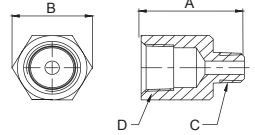

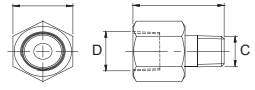

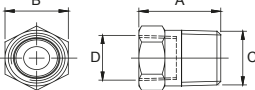

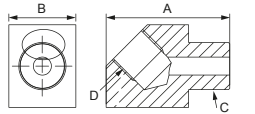
For PU, PE, PD and PG pumps

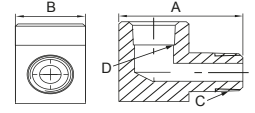

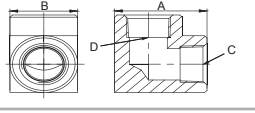
Valve Operation	Valve Type	Use w/ Cylinder	Model Number	Hydraulic Symbol	Schematic Flow path			Weight (kg)
Manual	3-Way, 2-Position	Single Acting	PUW2				-	1.81
	3-way, 3-Position, Tandem center	Single Acting	PUW3					1.81
	4-Way, 3-Position, Tandem center	Double Acting	PUW4					1.36
	3-Way, 3-Position, Tandem center, Locking	Single Acting	PUW33L					2.72
	4-Way, 3-Position, Tandem center, Locking	Double Acting	PUW43L					2.72

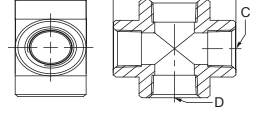
Fittings

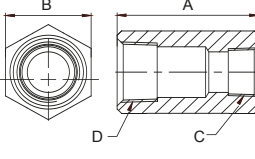
700 BAR Rated

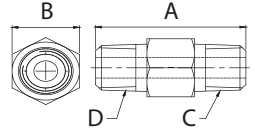
Fitting Type	Model Number	Dimensions				Display Image	
		A (mm)	B (mm)	C	D		
Adapters							
	Adapter 1/2"-14NPTF - Female 3/8"-18NPTF - Male	FT108	43	29	Male 3/8"-18NPTF	Female 1/2"-14NPTF	
	Adapter 1/2"-14NPTF - Female 1/4"-18NPTF - Male	FT118	43	29	Male 1/4"-18NPTF	Female 1/2"-14NPTF	
	Fitting	CA3814	35	23	Male 1/4"-18NPTF	Female 3/8"-18NPTF	
Bushings/Connectors							
	Bushing	CB1438	22	17	Male 3/8"-18NPTF	Female 1/4"-18NPTF	
	2 way 45° Connector Street Elbow, 3/8" to 3/8"- NPTF	FT045	28	22	Male 3/8"-18NPTF	Female 3/8"-18NPTF	
	2 way 90° Connector Street Elbow, 3/8" to 3/8"- NPTF	FT101 + FT101e	28	22	Male 3/8"-18NPTF	Female 3/8"-18NPTF	
	2 way 90° Connector Elbow, 3/8" to 3/8" - NPTF	FT107	48	26	Female 3/8"-18NPTF	Female 3/8"-18NPTF	
	3 Way Connector 3/8" to 3/8" - NPTF	FT106	46	26	Female 3/8"-18NPTF	Female 3/8"-18NPTF	
	4 Way Connector Cross, 3/8" to 3/8" - NPTF	FT105	36	26	Female 3/8"-18NPTF	Female 3/8"-18NPTF	
Couplings							
	Coupling Reducing Connector, 3/8" to 1/4" - NPTF	FT102	30	26	Female 1/4"-18NPTF	Female 3/8"-18NPTF	
	Coupling Reducing Connector, 1/2" to 3/8" - NPTF	FT112	48	29	Female 1/2"-14NPTF	Female 3/8"-18NPTF	
	Coupling 3/8" to 3/8" - NPTF	FT103	30	26	Female 3/8"-18NPTF	Female 3/8"-18NPTF	
Hex Nipples							
	Male Connector Hex Nipple, 1/4" to 1/4" - NPTF	FT104	38	17	Male 1/4"-18NPTF	Male 1/4"-18NPTF	
	Male Connector Hex Nipple, 3/8" to 3/8" - NPTF	FT114	38	19	Male 3/8"-18NPTF	Male 3/8"-18NPTF	
	Male Connector Hex Nipple, 1/4" to 3/8" - NPTF	FT124	37	19	Male 1/4"-18NPTF	Male 3/8"-18NPTF	

- Flow control valves
- Manifolds
- mano-meters adapters
- Hydraulic oil
- Pressure adjustment
- Foot pedal
- Couplers
- Hoses

- Valves
- Fittings



Hydraulic Manual Press

With easy system for the lifting of the work table

- The contra weight allows an effortless and fast positioning of the work table (↑↓).
- Designed and developed to relieve the operator from physical stress during lifting of the work table.
- Supplied with double speed pump, with 200mm long stroke hydraulic cylinder.
- Pump can be operated by hand, or by use of the foot pump lever.
- The pistons are made of chromium plated steel.
- Moveable ram

Model Number	Capacity	A (mm)	B (mm)	C (mm)	D (mm)	E (mm)	W (mm)	L (mm)	Weight (kg)
SMS3108	30 Tonne	2050	1100	710	200	1150	150	650	300
SMS5108	50 Tonne	2130	1200	810	200	1150	180	750	400
SMS10108	100 Tonne	2300	1530	1020	200	1000	265	850	950

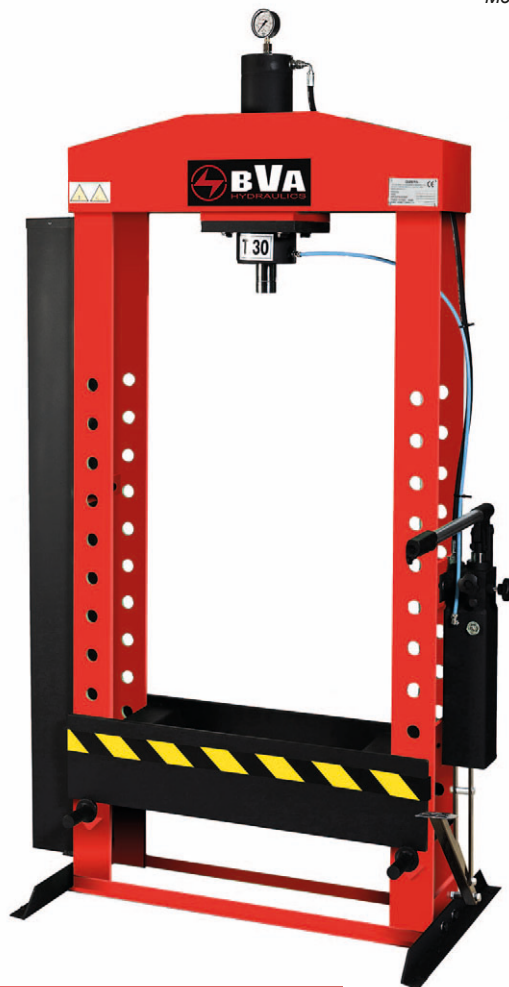
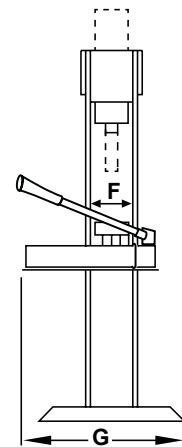
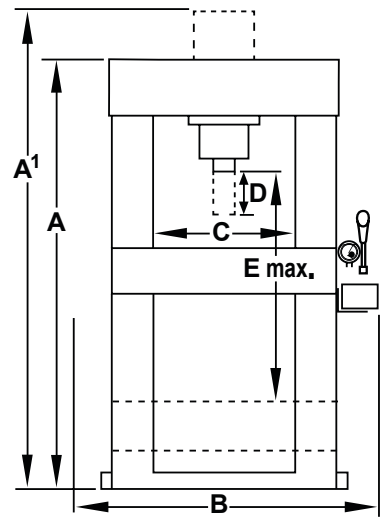

Optional Items

Open Safety Guard SAG51

Closed Safety Guard SAG51

Punch Set SAP31/SAP51

Adapter, 35 mm, 30 mm, 25 mm, 20 mm, 15 mm

80% **Safety Practices**
 Good industry practice recommends not exceeding 80% of maximum rated capacities of all our products.

Hydraulic Electrical Press

Electrical Press with Remote Control



SED10013

- New series of electrical presses with double acting cylinder.
- All presses are supplied with 2 "V" Arbor Plates and a punch plate.
- A moveable ram and winch to lift the work table is included with the presses.
- Remote control operation: easy and flexible operation by means of the remote control.

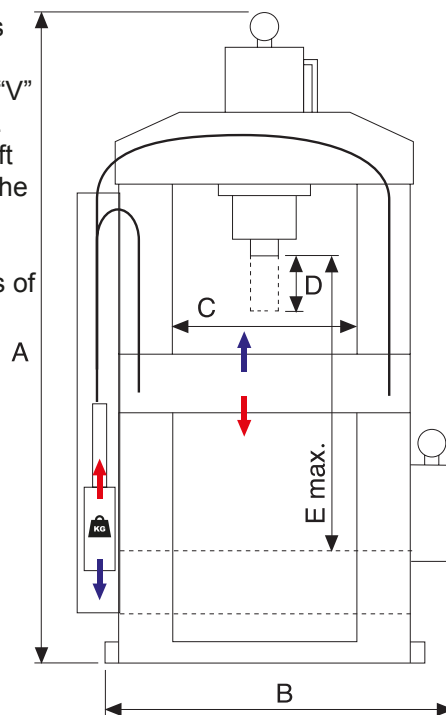

Model Number	Capacity	Cylinder	Pump	A (mm)	A1 (mm)	B (mm)	C (mm)	D (mm)	E (mm)	F (mm)	G (mm)	Weight (kg)
SED5513	50 Tonne	HD5513	PE0501	2000	2160	1580	785	335	1260	180	750	440
SED10013	100 Tonne	HD10013	PE1002	2100	2210	1900	1025	333	1150	270	850	1220



Electrical Press

Operating by: "Two" - hands

- Safe two hands operation.
- Flashing warning light - when operating.

Model Number	Capacity	Cylinder	Pump	A (mm)	A1 (mm)	B (mm)	C (mm)	D (mm)	E (mm)	F (mm)	G (mm)	Weight (kg)
SEC5513	50 Tonne	HD5513	PE0501	2000	2160	1580	785	335	1260	180	750	440
SEC10013	100 Tonne	HD10013	PE1002	2100	2210	1900	1025	333	1150	270	850	1220

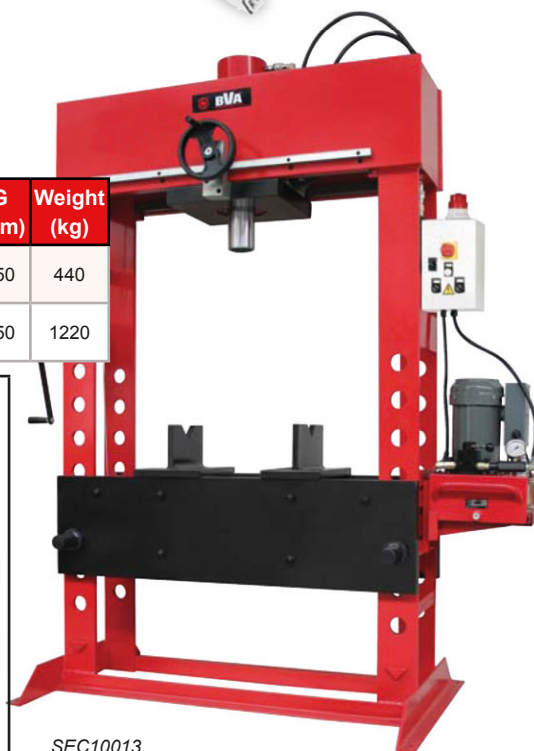

SEC10013



Punch Plate



Winch



Arbor Plates

Hydraulic press

Manual Puller

Hydraulic puller

Bolt puller kingpin press

Pad Eye tester

Valve Seat Puller

Spreader

Nut splitter

Mini Jacks Toe jacks

Bottle jacks

Impact sockets / Support pads



2 Leg Adjustable Puller

Manual Pullers

- Adjustable in width.

Model Number	Capacity	A (mm)	B (mm)	C (mm)	Weight (kg)
AMP120310	3 Tonne	100	95	134	1.1
AMP120315	3 Tonne	100	135	176	1.3
AMP120720	7 Tonne	150	160	223	3.5
AMP120725	7 Tonne	155	190	250	3.6
AMP121230	12 Tonne	205	240	325	7.5
AMP121235	12 Tonne	200	350	425	9
AMP121240	12 Tonne	200	510	585	15
AMP121550	15 Tonne	225	640	717	23

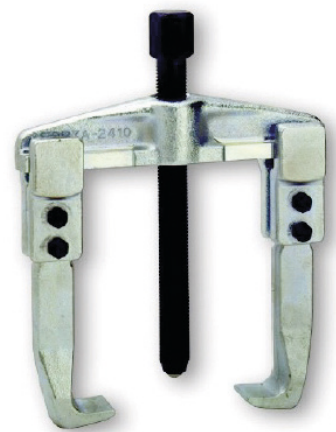
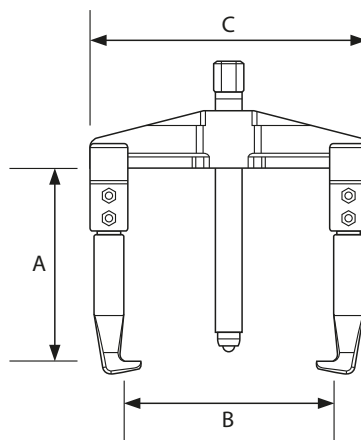

2/3 Leg Puller

Manual Pullers

- Can be used with either 2 or 3 jaws.
- The extra long jaws are adjustable in 4 positions.
- The jaws have a special cut-out to pull.

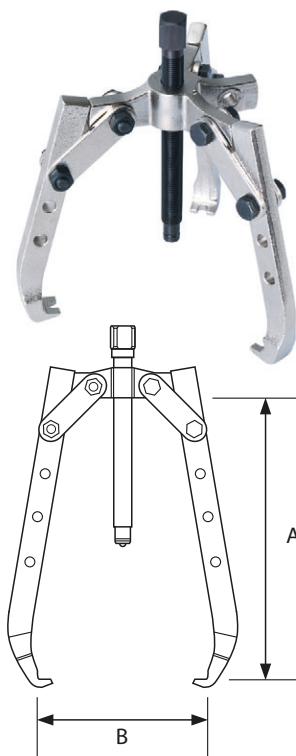
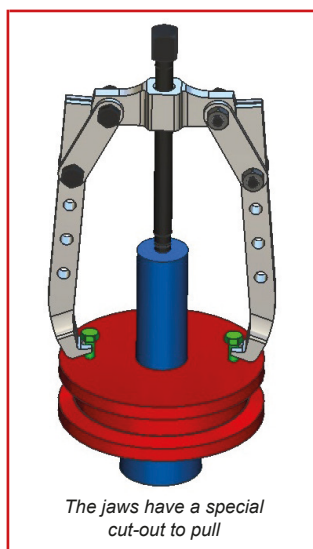

Model Number	Capacity (Tonne)	A (mm)	B (mm)	Weight (kg)
AMP230110	1	120	125	0.7
AMP230410	4	210	220	2.1
AMP230710	7	270	280	3.7
AMP230810	8	270	330	4.0

2/3 Leg Puller Self-Centering

Manual Pullers

Model Number	Capacity (Tonne)	A (mm)	B (mm)	Weight (kg)
AMPC230110	1	120	125	0.8
AMPC230410	4	210	220	2.1
AMPC230710	7	270	280	6.7

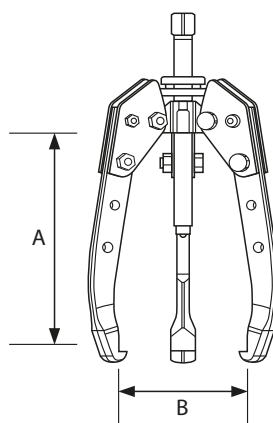

Push Puller

Manual Pullers

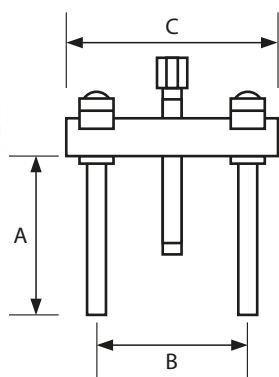
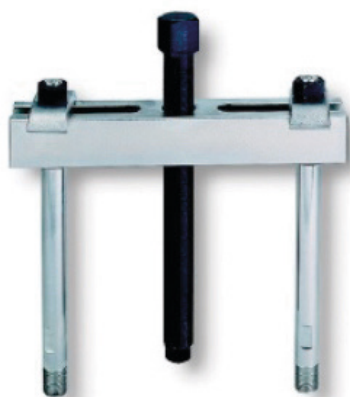

Model Number	A (mm)	B Max. (mm)	B Min. (mm)	C (mm)	Weight (kg)
AMP221102	120	110	46	122	1
AMP221103	120	140	46	156	1.1
AMP221110	190	195	62	210	3.4
AMP221130	225	445	173	475	12

Splitters

Manual Pullers

Model Number	A Max. (mm)	A Min. (mm)	B (mm)	R	Weight (kg)
APS1202	60	4	60	3/8"	0.7
APS1203	80	6	80	3/8"	1.3
APS1204	110	10	110	5/8"	2.7

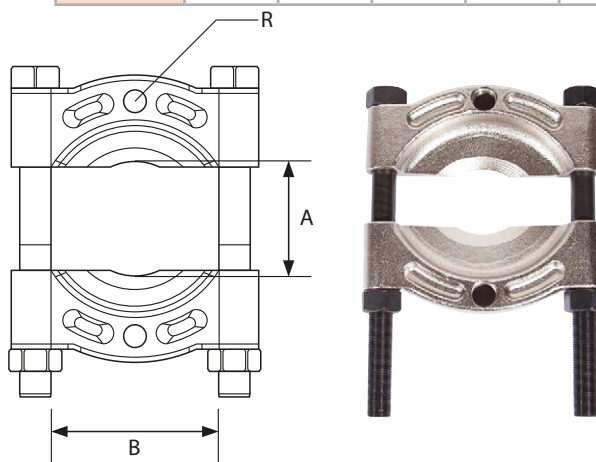

Splitters Set

Manual Pullers

Model Number	A (mm)	B (mm)	C (mm)
AMP320202	100	55	90
AMP320303	100	80	130
AMP321004	152	108	175

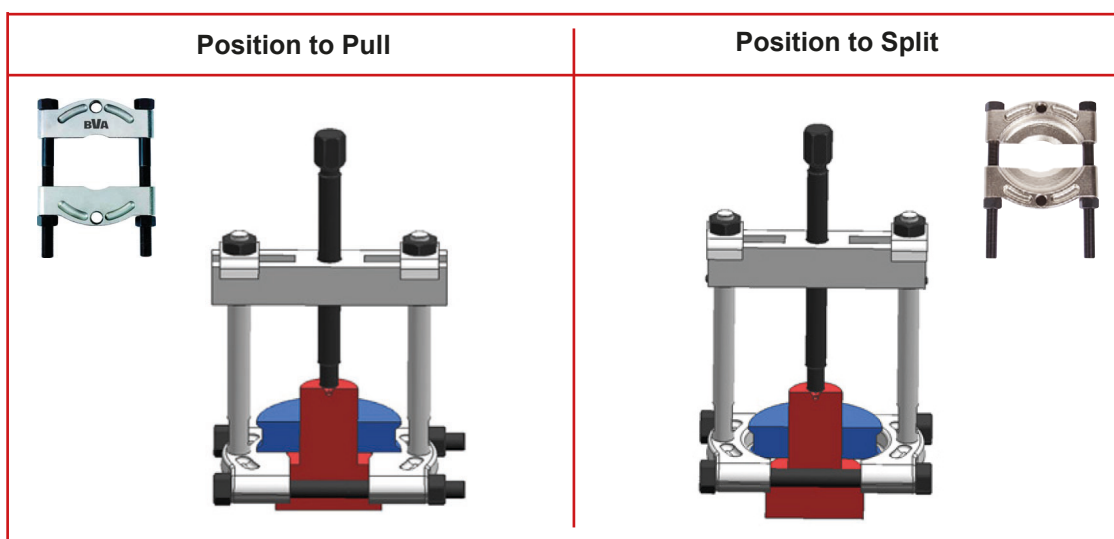
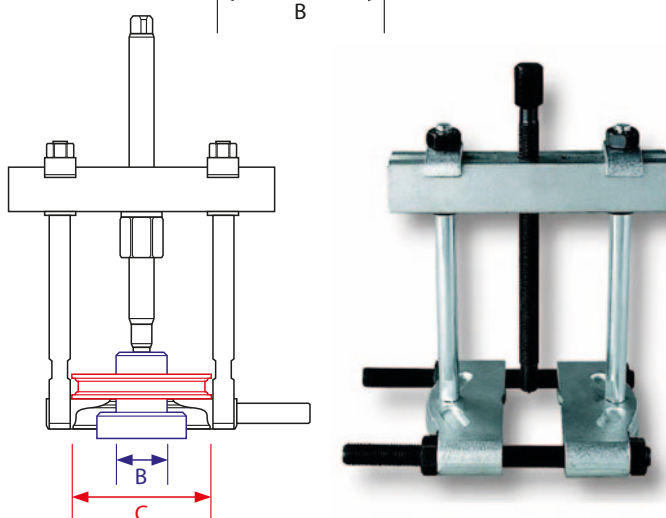

Note: Be sure to use the correct position for the required action in order to avoid damaging the Splitter-Set.

Hydraulic press

Manual Puller

Hydraulic puller

Bolt puller kingpin press

Pad Eye tester

Valve Seat Puller

Spreader

Nut splitter

Mini Jacks
Toe jacks

Bottle jacks

Impact sockets /
Support pads



Puller 2 Leg

Hydraulic Pullers (Excluding Cylinder)

- Pullers for Single Acting Cylinders.

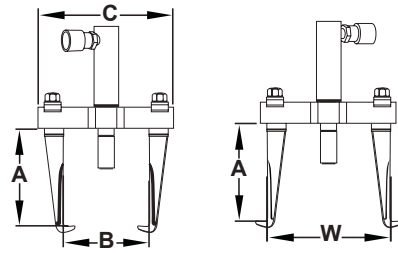

AP(L) 1205

Model Number	Cylinder (Optional)	Capacity (Tonne)	A (mm)	B Min. (mm)	B Max. (mm)	W (mm)	W (mm)	C (mm)	Weight (kg)
AP1205	H0503	5	160	60	200	175	270	260	8.5
APL1205	H0503	5	220	60	200	175	270	260	9.0



AP2205

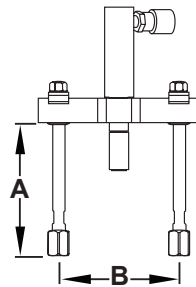

Model Number	Cylinder (Optional)	Capacity (Tonne)	A (mm)	B Min. (mm)	B Max. (mm)	Weight (kg)
AP2205	H0503	5	190	82	250	7.8

Splitters

Model Number	A Min. (mm)	A Max. (mm)	L (mm)	R (mm)	e (mm)	Weight (kg)
APS1204	10	110	110	15.9	2.5	2.8
APS1206	12	134	155	15.9	2.0	5.7



APS1204

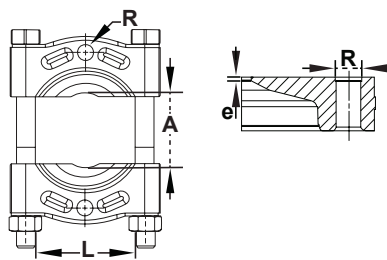

AP2205 + APS1204

Puller 2/3 Leg

Model Number	Cylinder (Optional)	Capacity (Tonne)	A (mm)	B Max. (mm)	Weight (kg)
AP1305	H0503	5	225	240	3.5
AP1310	H1004	10	400	350	9.5

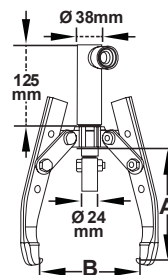

AP1305

Puller Kit

(Excluding Cylinder)

Content:

- 2/3 Leg Puller
- 2 Leg Puller
- Extensions for 2 Leg Puller
- Splitter

Puller Kit	Capacity (Tonne)	Image				Weight (kg)
		2/3 Leg Puller	2 Leg Puller	Extension Set	Splitter	
APK1005	5	AP1305	APL1205	APE1108+APE1118	APS1204	18



AP1305



APS1204



APE1118



APE1108



APL1205

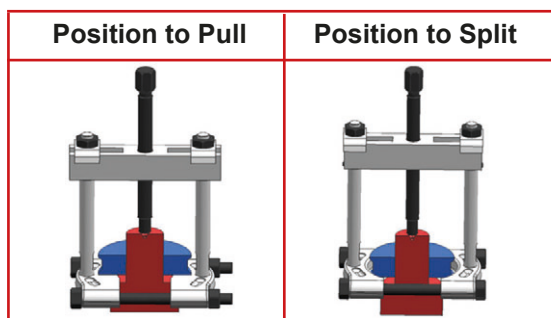

◀ Note: Be sure to use the correct position for the required action in order to avoid damaging the Splitter-Set.

Hydraulic Set - Single Acting Cylinder

Content:

- Handpump P350
- Cylinder H0503
- Gauge and Gauge adapter
- Adapter
- Hose
- Fitting and Coupler



APH0503

Hydraulic Set	Capacity (Tonne)	Image						Weight (kg)
		Handpump	Fitting	Gauge + Adapter	Hose	Coupler	Cylinder	
APH0503	5	P350	CA3814	GBW1460 + CF3814	CS3814-2	CH38-M	H0503	8

Hydraulic press

Manual Puller

Hydraulic puller

Bolt puller kingpin press

Pad Eye tester

Valve Seat Puller

Spreader

Nut splitter

Mini Jacks Toe jacks

Bottle jacks

Impact sockets / Support pads



Puller 2/3 and 3 Leg

(Excluding cylinder and APS threaded saddle)

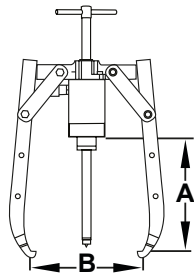

Model Number	Cylinder + APS saddle (Optional)	Capacity (Tonne)	Legs	A (mm)	B Max. (mm)	Weight (kg)
AP2310	HC1202	10	2/3	315	350	9
AP2320	HC2002T	20	3	320	480	23
AP2330	HC3002T	30	3	410	650	40
AP2360	HC6003T	60	3	710	980	87
APL2310	HC1202	10	2/3	400	410	10
APL2320	HC2002T	20	3	435	540	26
APL2330	HC3002T	30	3	535	720	46
APL2360	HC6003T	60	3	860	1080	96

Self-Centering Puller 2/3 and 3 Leg

Model Number	Cylinder + APS saddle (Optional)	Capacity (Tonne)	Legs	A (mm)	B Max. (mm)	Weight (kg)
APC2310	HC1202	10	2/3	315	350	14
APC2320	HC2002T	20	3	320	480	33
APC2330	HC3002T	30	3	410	650	56
APC2360	HC6003T	60	3	710	980	122
APC2399	HC10003T	100	3	1000	1600	322
APLC2310	HC1202	10	2/3	400	405	16
APLC2320	HC2002T	20	3	435	540	36
APLC2330	HC3002T	30	3	535	720	62
APLC2360	HC6003T	60	3	860	1080	131

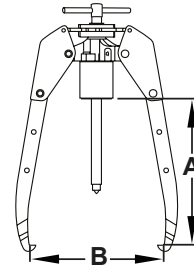

Application	
Splitter	Internal Puller

Puller Kit (Excluding Cylinder)

Puller Kit	Incl. 3-Leg Puller	Incl. Self-Centering 3-Leg Puller	Capacity (Tonne)
APK1010	APK1110	APK1210	10
APK1020	APK1120	APK1220	20
APK1030	APK1130	APK1230	30
APK1060	APK1160	APK1260	60
APK1099	-	APK1299	100

Content:

- 2 Leg Puller
- Extension Legs
- Splitter
- Internal Puller
- Joining Nuts
- Point Protection
- 2/3 Leg Puller (optional)





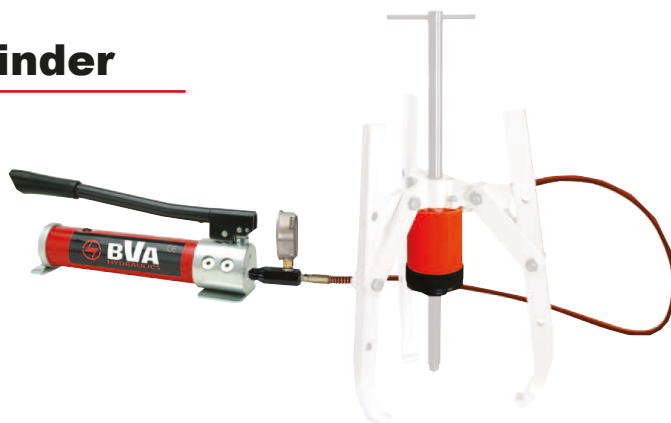

Hydraulic Set- Hollow Cylinder

Content:

- Handpump
- Hollow Cylinder
- Gauge and Gauge adapter
- Adapter
- Hose
- Fitting and Coupler



Model Number	Capacity (Tonne)							Weight (kg)
		Handpump	Gauge + Adapter	Hose	Coupler	Cylinder	Saddle	
APHC1202	10	P352	GBW1460 + CF3814	CS3814-2	CH38-M	HC1202	-	10
APHC2002	20	P352	GBW1460 + CF3814	CS3814-2	CH38-M	HC2002T	APS20	15
APHC3002	30	P352	GBW1460 + CF3814	CS3814-2	CH38-M	HC3002T	APS30	18
APHC6003	60	P1000	GBW1460 + CF3814	CS3814-2	CH38-M	HC6003T	APS60	46
APHC10003	100	P2301	GBW1460 + CF3814	CS3814-2	CH38-M	HC10003T	-	73

Hydraulic press

Manual Puller

Hydraulic puller

Bolt puller kingpin press

Pad Eye tester

Valve Seat Puller

Spreader

Nut splitter

Mini Jacks Toe jacks

Bottle jacks

Impact sockets / Support pads



Composition Hydraulic Puller Kits

(Excluding Hydraulics) See also page 79

Model Number	Capacity (Tonne)									Weight (kg)
		3 or 2/3 Leg Puller Self-Centering	3 or 2/3 Leg Puller	2 Leg Puller	2x Extender Set	Splitter	Internal Puller	Joining Nuts	Point Protection	
APK1010	10			AP2210	APE1120 + APE1146	APS1204	API1210	AJN05	APP10	35
APK1020	20			AP2220	APE1220 + APE1252	APS1206	API1220	AJN10	APP20	60
APK1030	30			AP2230	APE1333 + APE1358	APS1210	API1230	AJN30	APP30	120
APK1060*	60			AP2250	APE1550 + APE1582	APS1210D	API1250	AJN50	APP30	215
APK1061*	60			AP2250	APE1550 + APE1582	APS1212	API1250	AJN50	APP30	230
APK1110	10		AP2310 (2/3 Leg)	AP2210	APE1120 + APE1146	APS1204	API1210	AJN05	APP10	44
APK1120	20		AP2320 (3 Leg)	AP2220	APE1220 + APE1252	APS1206	API1220	AJN10	APP20	83
APK1130	30		AP2330 (3 Leg)	AP2230	APE1333 + APE1358	APS1210	API1230	AJN30	APP30	160
APK1160*	60		AP2360 (3 Leg)	AP2250	APE1550 + APE1582	APS1210D	API1250	AJN50	APP30	302
APK1161*	60		AP2360 (3 Leg)	AP2250	APE1550 + APE1582	APS1212	API1250	AJN50	APP30	317
APK1210	10	APC2310 (2/3 Leg)		AP2210	APE1120 + APE1146	APS1204	API1210	AJN05	APP10	50
APK1220	20	APC2320 (3 Leg)		AP2220	APE1220 + APE1252	APS1206	API1220	AJN10	APP20	93
APK1230	30	APC2330 (3 Leg)		AP2230	APE1333 + APE1358	APS1210	API1230	AJN30	APP30	177
APK1260*	60	APC2360 (3 Leg)		AP2250	APE1550 + APE1582	APS1210D	API1250	AJN50	APP30	349
APK1261*	60	APC2360 (3 Leg)		AP2250	APE1550 + APE1582	APS1212	API1250	AJN50	APP30	364

* Available on request: no stock item

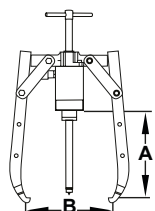

Model Number	Capacity (Tonne)	A (mm)	B Min. (mm)	B Max. (mm)	Weight (kg)
AP2310	10	315	50	350	9
AP2320	20	320	70	480	23
AP2330	30	410	90	650	40
AP2360	60	710	120	980	87

3 Leg Pullers

3 Leg Self-Centering Pullers

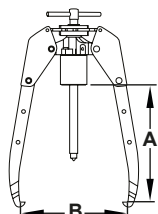

Model Number	Capacity (Tonne)	A (mm)	B Min. (mm)	B Max. (mm)	Weight (kg)
APC2310	10	315	50	350	14
APC2320	20	320	70	480	33
APC2330	30	410	90	650	56
APC2360	60	710	120	980	122

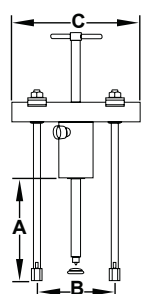

Model Number	Capacity (Tonne)	A (mm)	B Min. (mm)	B Max. (mm)	C (mm)	Weight (kg)
AP2210	10	300	115	260	280	7.5
AP2220	20	265	140	345	370	18.5
AP2230	30	284	180	440	480	37
AP2250	50	447	220	580	615	70.5

2 Leg Pullers

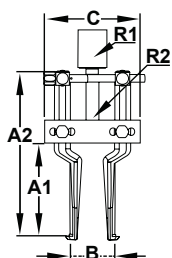

Model Number	A1 (mm)	A2 (mm)	B Min. (mm)	B Max. (mm)	C	R1	R2	Weight (kg)
API1210	115	237	40	145	133	3/4" UNF 16h	5/8" 14h	2.0
API1220	115	237	40	145	133	1" UNF 8h	5/8" 14h	2.4
API1230	150	310	60	240	202	1 1/4" UNF 7h	1" 14h	6.0
API1250	150	310	60	240	202	1 1/8" UNS 5.5h	1" 14h	6.4

Internal Pullers

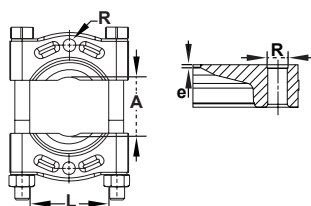

Model Number	A Min. (mm)	A Max. (mm)	L (mm)	R (mm)	e (mm)	Weight (kg)
APS1204	10	110	110	15.9	2.5	2.8
APS1206	12	134	155	15.9	2	5.7
APS1210	17	250	260	25.4	4	28.5
APS1210D	17	250	260	31.8	4	28.5
APS1212	35	300	300	31.8	4.5	43.5

Splitters

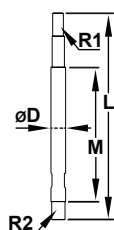

Model Number	L (mm)	M (mm)	Ø D (mm)	R1	R2
APE1120	209	106	25	3/4" - 16h	5/8" - 18h
APE1220	209	89	25	3/4" - 16h	5/8" - 18h
APE1333	328	158	32	1" - 14h	1" - 14h
APE1550	504	292	42	1 1/4" - 12h	1 1/4" - 12h
APE1146	460	357	25	3/4" - 16h	5/8" - 18h
APE1252	515	395	25	3/4" - 16h	5/8" - 18h
APE1358	582	412	32	1" - 14h	1" - 14h
APE1582	820	608	42	1 1/4" - 12h	1 1/4" - 12h

Leg Extensions



Hydraulic press

Manual Puller

Hydraulic puller

Bolt puller kingpin press

Pad Eye tester

Valve Seat Puller

Spreader

Nut splitter

Mini Jacks Toe jacks

Bottle jacks

Impact sockets / Support pads



Hydraulic Gear Pullers

- Forged high strength puller body, with integral safety valve & red warning line.
- Heat treated forged alloy steel components with manganese phosphate coating for increased corrosion & wear resistance and extend working life. 120% rated capacity for jaws.
- Can be ordered with or without complete hydraulic set.
- Material lifetime warranty.
- Supplied with protective carrying case.
- 2 or 3 Jaw puller can be used for multiple pulling applications. (2 Jaw where space is constricted).

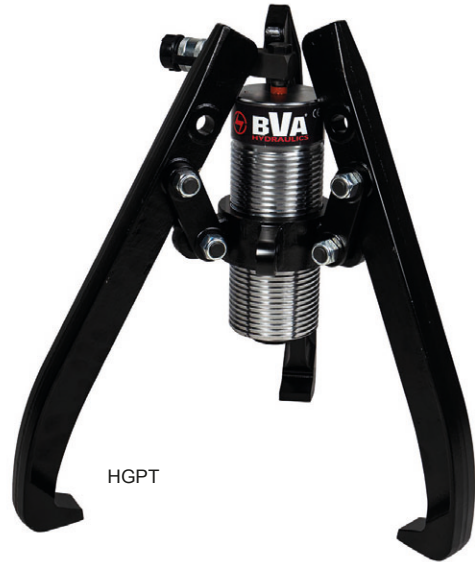

HGPT

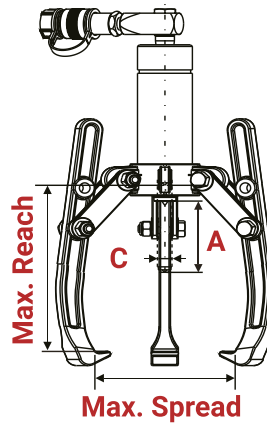
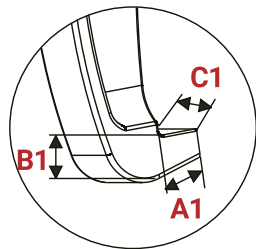
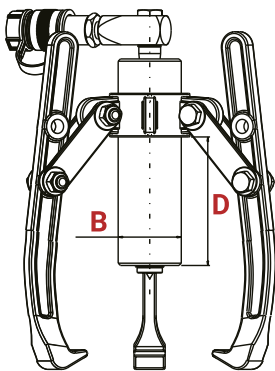

Model Number	Capacity (Tonne)	Stroke (mm)	Eff Area (cm ²)	Max. Reach (mm)	Max. Speed (mm)	Tip (mm)			Jaw Tip (mm)			Net. Weight (kg)
						B	C	D	A1	B1	C1	
HGPT06	6	70	8.04	245	330	45	23	91	13	10	22	5.4
HGPT12	12	85	14.45	260	375	60	28	118	14	10	29	9.5
HGPT20	20	111	28.26	350	520	80	40	162	20	27	33	23
HGPT30	30	111	42	435	550	98	50	155	20	27	38	35.3
HGPT50	50	143	71.22	635	1000	127	79	235	43	16	32	110



Bolt Puller/King Pin Press

30 Tonne & 60 Tonne (Excluding Cylinder)

Bolt Puller/King Pin Press (excluding hydraulics).
Ideal for pushing King Pin and Stub Axle Pin replacement.
Mobile and easy to use in the field or workshop.

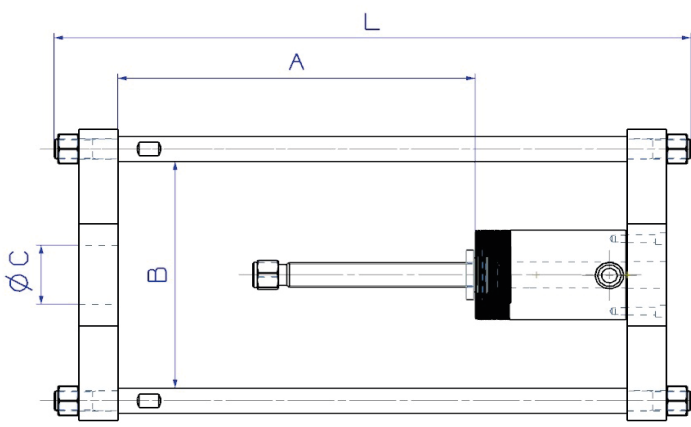
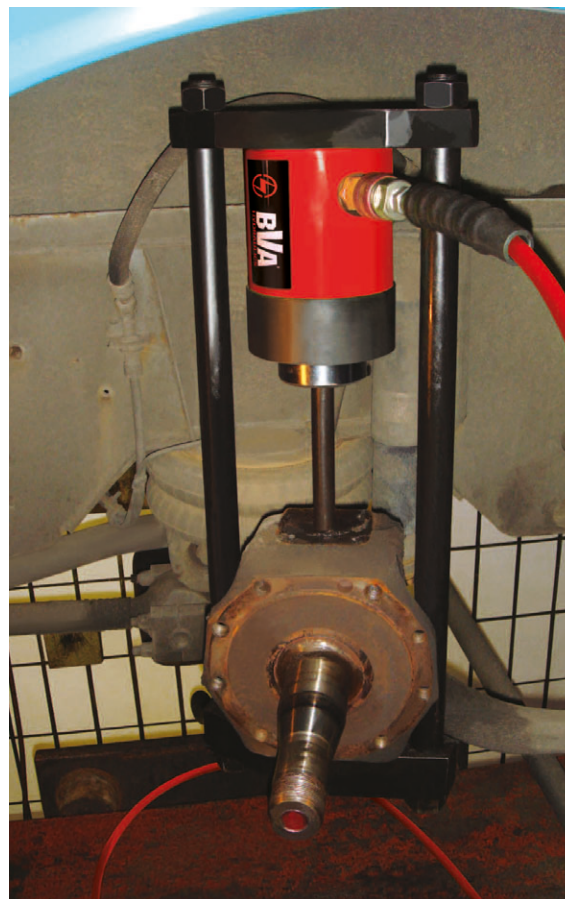

Model Number	A (mm)	B (mm)	Ø C (mm)	D (mm)	E (mm)	F (mm)	L (mm)	Weight (kg)
AP2239	420	288	75	370	92.1	118	750	36
AP2269	475	398	98	520	130.2	170	900	97

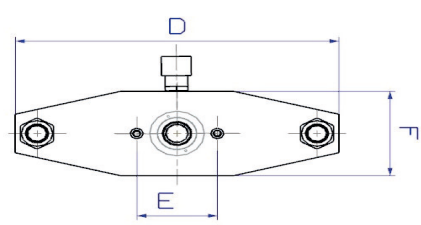

Hydraulic Set is not included
We recommend the following set:

Model Number	Capacity (Tonne)	Recommended Components								Weight (kg)
		Handpump	Fittings	Gauge + Adapter	Hose	Coupler	Cylinder	Saddle		
APHC3002	30	P350	CA3814	GBW1460 + CF3814	C3814-2	CH38-M	HC3002T	APS30	18	
APHC6003	60	P1000	-	GBW1460 + CF3814	C3814-2	CH38-M	HC6003T	APS60	46	

- Hydraulic press
- Manual Puller
- Hydraulic puller
- Bolt puller kingpin press
- Pad Eye tester
- Valve Seat Puller
- Spreader
- Nut splitter
- Mini Jacks Toe jacks
- Bottle jacks
- Impact sockets / Support pads



Pad Eye Tester

20,30 & 60 Tonne (Including hydraulic set)



- Test lifting/anchor points in upright, horizontal or inverted applications.
- Available in 20, 30 and 60 ton.
- Including pump, hose, connectors and load specific manometer.
- Packed in wooden crate for easy storage.
- Equipped with lifting handles for easy handling.
- Versatile applications and easy to use.

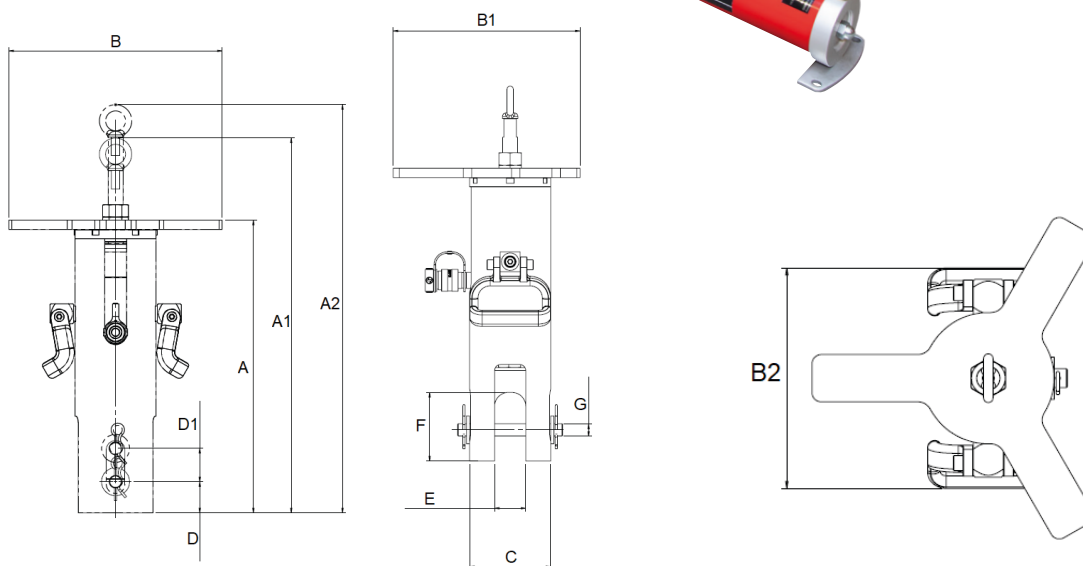

Model Number	Capacity Tonne	A	A1	A2	B	B1	B2	C	D	D1	E	F	G
CT3220T	20	470	602	656	343	300	235	130	50	54	50	110	20
CT3230T	30	531	682	746	343	300	256	150	50	64	60	120	25
CT3260T	60	630	802	869	343	300	308	202	50	67	65	150	40

Valve Seat Puller

Frac Pump Maintenance



HVSP120



HVSP125

- Pump kit to operate HVSP Series cylinders. Part number: SP12-CSG4
- Pump kit includes: P1201, CS3814-2, CH38M, GBW1460 and CF3814

Cylinder Capacity (tonne)	Model Number	Center Hole ID (mm)	Stroke (mm)	Collapsed Height (mm)	Weight (kg)
120	HVSP120	54	15.4	92	27.9
125	HVSP125	54	15.4	92	24.5

Flange Spreader

Pin Type (Including Cylinder)

- Designed for heavy duty industrial environment
- Adjustable jaw width for a wide range of applications and easy use
- Spare wedge attachment is included

Capacity	Model Number	Stroke (mm)	Oil Capacity (cc)	Maximum Flange Thickness (mm)
5 Tonne 45 kN	HFS05	25	16	51 X 58
10 Tonne 101 kN	HFS10	51	74	51 X 91

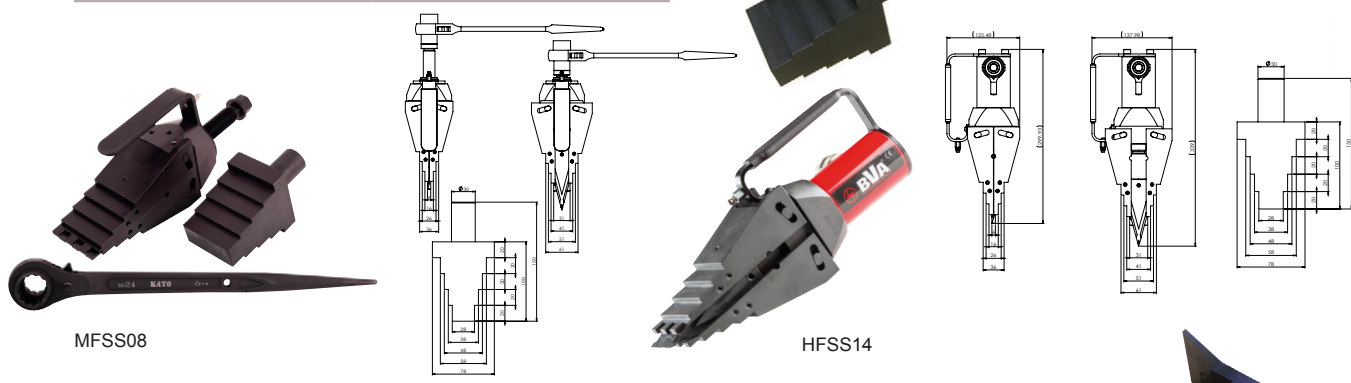

Model Number	Type	Maximum Spreading Force	Spreading Distance Maximum* (mm)	Flange Dimensions Minimum Access Gap A (mm)	Jaw Width (mm)	Tool Weight (kg)	Oil Capacity (CC)
MFSS08	Mechanical	78	80	6	60	6.2	N/A
HFSS14	Hydraulic	137	80	6	60	10.2	74

* Using CFSS02 stepped blocks.

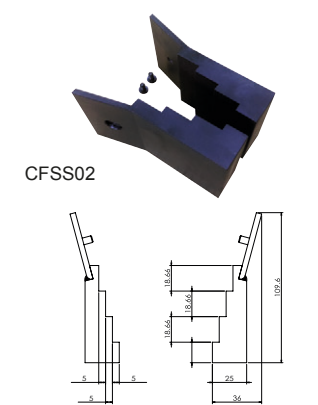

Spreaders

- Designed to work in confined work spaces
- Ideal for wedging, prying and opening
- High strength forged steel
- Spring return for easy operation

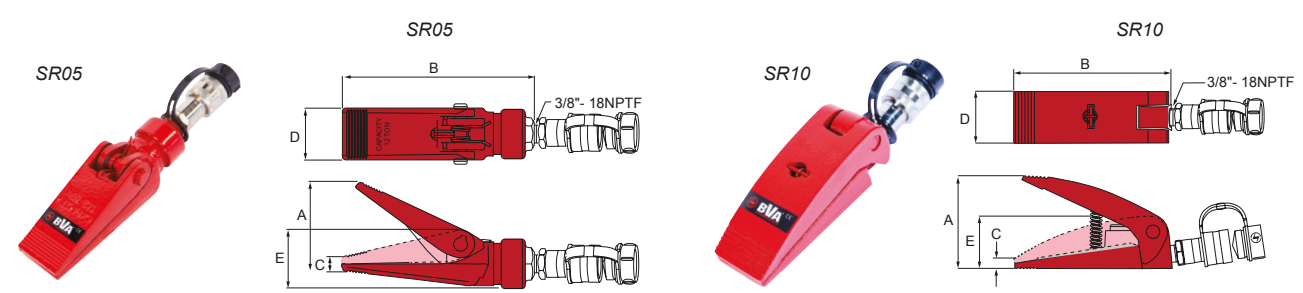

Cylinder Capacity	Model Number	Cylinder Effective Area (cm ²)	Oil Capacity (cc)	Dimensions (mm)					Weight (kg)
				A	B	C	D	E	
0.5 Tonne 4.9 kN	SR05	7.87	10	90	192	13	52	60	2.2
1 Tonne 9.8 kN	SR10	7.03	14	99	167	12	55	56	2.3

- Hydraulic press
- Manual Puller
- Hydraulic puller
- Bolt puller kingpin press
- Pad Eye tester
- Valve Seat Puller
- Spreader
- Nut splitter
- Mini Jacks Toe jacks
- Bottle jacks
- Impact sockets / Support pads



Hydraulic Nut Splitter Case

Compact and Heavy Duty

- Spacers include a straight chisel with a 60/40 angle, and works on all type of materials, including stainless steel
- Chisel can be re-sharpened multiple times
- The aluminum flight case also includes one spare blade



Our Recommendation

This combination kit will work well with this foot pump



P570FP

pg 46

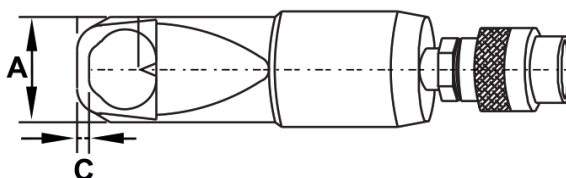
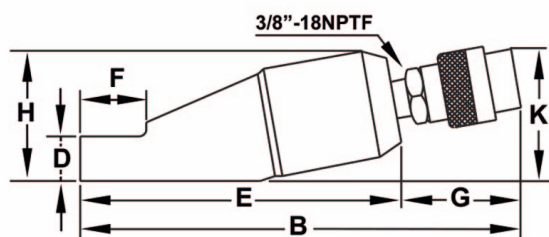

Model Number	Capacity (Tonne)	Bolt Range	Hexagon Nut Range (mm)	Oil Capacity (cc)	Dimensions (mm)									Replacement Blade Model Number	Weight (kg)
					A	B	C	D	E	F	G	H	K		
NS1319	6	M6-M12	13-19	11	40	190	7	19	121	28	55	48	57	NSB1319	1
NS1924	10	M12-M16	19-24	17	54	217	10	26	146	40	55	62	60	NSB1924	2
NS2432	15	M16-M22	24-32	40	64	245	13	29	178	51	55	72	71	NSB2432	3.2
NS3241	21	M22-M27	32-41	62	75	260	17	36	205	66	55	88	77	NSB3241	4.7
NS4150	34	M27-M33	41-50	123	94	310	21	45	244	74	55	105	90	NSB4150	8.5
NS5060*	49	M33-M39	50-60	191	106	335	23	54	289	90	55	128	100	NSB5060	13
NS6075*	93	M39-M48	60-75	650	156	410	26	72	365	110	55	181	124	NSB6075	34

* Available on request. (no stock item)

BVA Bag

- Very practical for service people.
- For easy and comfortable carry/transport of the equipment to the place of work while keeping your hands free.



71 cm

25 cm

15 cm

Mini Jacks

Compact

- Low profile mini jack
- Compact and lightweight
- Convenient for storage



These mini jacks are lightweight and will fit in the palm of your hand.



Capacity	Model Number	Minimum Height (mm)	Maximum Height (mm)	Hydraulic Lifting (mm)	Base Size (L x W) (mm)	Weight (kg)
5 Tonne 49 kN	J11050	60	80	20	124 x 116	2.1
5 Tonne 49 kN	J11055	85	123	38	124 x 116	2.4
10 Tonne 99 kN	J11100	122	163	41	125 x 112	5.7
20 Tonne 199 kN	J11200	130	171	41	137 x 122	7.6

Toe Jacks

Low Height

- Heat treated and chrome plated medium-carbon steel cylinder.
- Chrome plated plunger improves longer seal life and optimum performance.
- U.S. Patented by-pass device protects hydraulic system from over travel damage.
- Hydraulic system is protected from internal damage by a patented by-pass mechanism (U.S. Patent No.5946912).



Capacity	Model Number	Toe Saddle		Head Saddle		Hydraulic Lifting (mm)	Base Size (L x W) (mm)	Weight (kg)
		Min. Height (mm)	Max. Height (mm)	Min. Height (mm)	Max. Height (mm)			
3 Tonne / 29 kN	J13060	15	147	229	358	130	152 x 112	16.4
6 Tonne / 59 kN	J13120	23	152	267	396	130	279x 191	24.9
10 Tonne / 99 kN	J13200	28	160	279	409	130	295 x 229	38.1
15 Tonne 149 kN	J13300	28	168	333	472	130	318 x 274	52.9

Hydraulic press

Manual Puller

Hydraulic puller

Bolt puller kingpin press

Pad Eye tester

Valve Seat Puller

Spreader

Nut splitter

Mini Jacks Toe jacks

Bottle jacks

Impact sockets / Support pads



Manual Bottle Jacks



- With easy adjustable extension screw [12-20 Tons].
- With rubber removable carry ring for easy storage of pump handle [2-20 Tons].
- Safety valve against over-loading.
- Bottle Jacks 8 Ton and more are supplied with a carry grip.

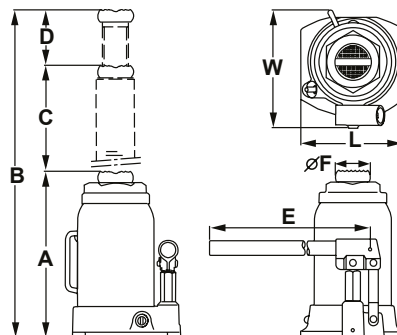

Model Number	Capacity	A (mm)	B (mm)	C (mm)	D (mm)	E (mm)	F (mm)	L (mm)	W (mm)	Weight (kg)
1412000	12 Tons 119 kN	241	469	150	78	345	42	138	106	7.4
1420000	20 Tons 199 kN	249	475	150	76	452	76	160	150	12.9
10500	50 Tons 498 kN	305	483	178	-	593	79	275	198	50.4
10990	100 Tons 996 kN	305	461	156	-	600	113	305	238	90.6

Air operated bottle jacks

- 20 - 30 Ton
- 8 - 12 bar suggested air pressure for optimal performance.

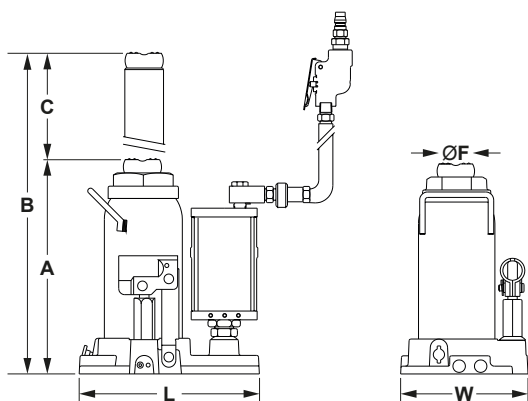

Model Number	Capacity	A (mm)	B (mm)	C (mm)	D (mm)	E (mm)	F (mm)	L (mm)	W (mm)	Weight (kg)
18202C	20 Tons 199 kN	247	477	130	100	600	48	216	184	17
18206C	20 Tons 199 kN	245	478	80	153	600	52	230	173	17.6
17302C	30 Tons 298 kN	280	458	180	-	965	62	210	210	27.5

Maintenance Kits

4, 10 Ton

- Sets are portable for ease of use on the job site
- Custom fitted, rugged blow molded storage case
- 10 ton set has wheels for easy transport
- Designed for pushing, spreading, pressing and more



Capacity	Pump Capacity (BAR)	Model Number	Plunger			Number of Attachments	Weight (kg)
			Collapsed Height (cm)	Extended Height (mm)	Effective Area (cm ²)		
4 Tons 39 kN	552	50040	70.97	258	6.44	14	21
10 Tons 98 kN	700	50100	87.94	324	15.56	13	36.7

* When extension tubes and/or offset attachments are used, the capacity is reduced.

- Hydraulic press
- Manual Puller
- Hydraulic puller
- Bolt puller kingpin press
- Pad Eye tester
- Valve Seat Puller
- Spreader
- Nut splitter
- Mini Jacks Toe jacks
- Bottle jacks
- Impact sockets / Support pads



Impact sockets

- All our Impact Sockets are manufactured with UNI-ISO 1174 & DIN 3121 standards.
- Manufactured with only high alloy steel.
- Special sockets on request available.



Model	Model Number	Drive	mm																			
			17	19	22	24	27	30	32	33	36	41	46	50	55	60	65	70	75	80	85	90
Standard Socket Metric	BSD34-(mm)	¾"	x	x	x	x	x	x	x	x	x	x	x	x	x	x						
	BSD100-(mm)	1"		x	x	x	x	x	x	x	x	x	x	x	x	x	x	x	x	x	x	x
	BSD112-(mm)	1" ½							x	x	x	x	x	x	x	x	x	x	x	x	x	x
	BSD212-(mm)	2" ½													x	x	x	x	x	x	x	x
Long Socket Metric	BSD34-(mm)L	¾"	x ¹	x ¹	x ¹	x ¹	x ¹	x ¹	x ¹	x ¹	x ¹	x ¹	x ¹	x ¹	x ¹	x ²						
	BSD100-(mm)L	1"		x ¹	x ¹	x ¹	x ¹	x ¹	x ¹	x ¹	x ¹	x ¹	x ³	x ³	x ⁴	x ⁴	x ⁴	x ⁵	x ⁵	x ⁵	x ⁶	x ⁶
	BSD112-(mm)L	1" ½										x ⁷	x ⁷	x ⁷	x ⁷	x ⁷	x ⁷	x ⁸	x ⁸	x ⁸	x ⁹	x ⁹

Model	Model Number	Drive	mm																			
			95	100	105	110	115	120	125	130	135	140	145	150	155	160	165	170	175	180	185	190
Standard Socket Metric	BSD34-(mm)	¾"																				
	BSD100-(mm)	1"	x	x																		
	BSD112-(mm)	1" ½	x	x	x	x	x	x	x	x	x	x	x	x	x							
	BSD212-(mm)	2" ½	x	x	x	x	x	x	x	x	x	x	x	x	x	x	x	x	x	x	x	x
Long Socket Metric	BSD34-(mm)L	¾"																				
	BSD100-(mm)L	1"	x ⁶	x ⁷																		
	BSD112-(mm)L	1" ½	x ¹⁰	x ¹⁰	x ¹⁰	x ¹¹	x ¹¹	x ¹¹	x ¹¹	x ¹¹	x ¹¹	x ¹²	x ¹²	x ¹²	x ¹²	x ¹²						

Length of Socket (mm) x¹ 100 x² 110 x³ 115 x⁴ 125 x⁵ 135 x⁶ 140 x⁷ 150 x⁸ 170 x⁹ 180 x¹⁰ 190 x¹¹ 200 x¹² 210

Imperial sizes, Allen Sockets or Reducer Sockets are available on request
size and dimensions are available on request



Model	Model Number	Drive	Length in Inch/mm							
			7"/175	10"/250	12"/300	13"/330	15"/380	18"/455	24"/610	
Standard Socket Metric	BSD34-(Inch)	3/4"	x	x		x				
	BSD100-(Inch)	1"	x	x		x				
	BSD112-(Inch)	1" 1/2		x			x	x		
	BSD212-(Inch)	2" 1/2				x		x	x	

Support Pads

Stability solutions



The support pads are outrigger pads used for mobile cranes, truck mounted cranes, aerial working platforms, concrete pumps, containers, hydraulic jacks etc.

Its purpose is to spread the weight over a larger surface offering better support while also protecting the surface.

Support Pads	Model Number	Grip	Dimension (mm)	Weight (kg)	Capacity (Tonne)
	SP 44410	1	400 x 400 x 40	6	10
	SP 55415	1	500 x 500 x 40	9	15
	SP 66420	1	600 x 600 x 40	14	20
	SP 66625	1	600 x 600 x 60	20	25
	SP 1010650*	2	1000 x 1000 x 60	58	50

Other sizes/capacities available on request.

* Not standard stock item.

Support Pads

Stability solutions

- Ecological
- Light weight
- Easy to handle
- High durability
- High flexibility
- Water-repellent
- Nearly unbreakable
- No rusting
- No Rotting

Safety Practices

Good industry practice recommends not exceeding 80% of maximum rated capacities of all our products.



Hydraulic press

Manual Puller

Hydraulic puller

Bolt puller kingpin press

Pad Eye tester

Valve Seat Puller

Spreader

Nut splitter

Mini Jacks Toe jacks

Bottle jacks

Impact sockets / Support pads



Pumps / Cylinders Operation and Speed Chart

NUMBER OF STROKE PER CM OF CYLINDER PLUNGER TRAVEL																
Model Number	5 Tonne		10 Tonne		15 Tonne		25 Tonne		30 Tonne		50 Tonne		75 Tonne		95 Tonne	
	No load	Load	No load	Load	No load	Load	No load	Load	No load	Load	No load	Load	No load	Load	No load	Load
POWER SOURCE: MANUAL																
P601S	3	3	6	6	9	9	14	14	17	17	29	29	42	42	54	54
P350	2	8	5	18	7	25	11	41	13	52	22	87	32	127	41	162
P1000	1	3	2	7	2	9	3	15	4	19	6	31	8	46	11	58
P1201	1	3	2	7	2	9	3	15	4	19	6	31	8	46	11	58
P2301/P2301M	1	3	2	7	2	9	3	15	4	19	6	31	8	45	10	58
P4301/P4301M	1	3	2	7	2	9	3	15	4	19	6	31	8	46	11	58
P8701/P8701M	0.1	1.4	0.2	3.4	0.2	4.3	0.3	7	0.4	9	0.6	15	0.8	22	1.1	28

SECONDS PER CM OF CYLINDER PLUNGER TRAVEL																
Model Number	5 Tonne		10 Tonne		15 Tonne		25 Tonne		30 Tonne		50 Tonne		75 Tonne		95 Tonne	
	No load	Load	No load	Load	No load	Load	No load	Load	No load	Load	No load	Load	No load	Load	No load	Load
POWER SOURCE: AIR (BASED ON 7 BAR AIR PRESSURE)																
PA600/PA600H	0.4	2.6	0.9	5.8	1.2	8.1	2	13.3	2.5	16.8	4.2	28.3	6.2	41.6	8	53.1
PA1500	0.4	2.1	0.9	4.8	1.2	6.8	2	11.1	2.5	14	4.2	23.6	6.2	34.6	8	44.2
PA1500M	0.4	2.6	0.9	5.8	1.2	8.1	2	13.3	2.5	16.8	4.2	28.3	6.2	41.6	8	53.1
PA2000	0.4	2.6	0.8	5.8	1.1	8.1	1.9	13.3	2.3	16.8	4	28.3	5.8	41.6	7.4	53.1
PA3801/PA3801M	0.4	2.6	0.8	5.8	1.1	8.1	1.9	13.3	2.3	16.8	4	28.3	5.8	41.6	7.4	53.1
PA1500L/PA3801L	0.4	2.3	1	5.4	1.4	7.6	2.2	12.5	2.8	15.7	4.7	26.6	6.9	39	8.8	49.8
PA7550/PA7550M	0.4	2.6	0.8	5.8	1.1	8.1	1.9	13.3	2.3	16.8	4	28.3	5.8	41.6	7.4	53.1
POWER SOURCE: ELECTRIC (SPEED BASED ON 50HZ)																
PE30S...	0.1	1.5	0.2	3.3	0.2	4.6	0.4	7.6	0.5	9.6	0.9	16.2	1.3	23.8	1.6	30.4
PE40S...	0.1	0.7	0.2	1.7	0.2	2.4	0.4	3.9	0.5	4.9	0.9	8.2	1.3	12.1	1.6	15.4
PE50S...	0.1	0.5	0.1	1	0.2	1.5	0.3	2.4	0.4	3	0.7	5.1	1	7.5	1.2	9.5
PE60S...	0.05	0.2	0.1	0.6	0.2	0.8	0.3	1.3	0.3	1.6	0.5	2.7	0.8	4	1	5.1
PE30M...	0.1	1.6	0.2	3.5	0.3	5	0.5	8.1	0.6	10.2	1.1	17.3	1.6	25.3	2	32.4
PE40M...	0.09	0.8	0.2	1.8	0.3	2.5	0.5	4	0.6	5.1	1	8.6	1.5	12.7	1.9	16.2
PE50M...	0.06	0.5	0.1	1.1	0.2	1.5	0.3	2.4	0.4	3.1	0.7	5.2	1	7.6	1.3	9.7
PE60M...	0.05	0.3	0.1	0.6	0.2	0.8	0.3	1.3	0.4	1.7	0.6	2.9	0.9	4.2	1.1	5.4
POWER SOURCE: ROTARY AIR (BASED ON 7 BAR AIR PRESSURE)																
PARD17--	0.04	1	0.1	2.4	0.1	3.3	0.2	5.4	0.3	6.8	0.5	11.5	0.7	16.8	0.9	21.5
PARD40--	0.03	0.3	0.1	0.8	0.1	1.1	0.1	1.7	0.2	2.2	0.3	3.7	0.4	5.4	0.5	6.9
PAR17--	0.04	1	0.1	2.4	0.1	3.3	0.2	5.4	0.3	6.8	0.4	11.5	0.6	16.8	0.8	21.5
PAR40--	0.03	0.3	0.1	0.8	0.1	1.1	0.1	1.7	0.2	2.2	0.3	3.7	0.4	5.4	0.5	6.9
POWER SOURCE: GASOLINE																
PG5505/PD3505	0.03	0.2	0.1	0.5	0.1	0.8	0.2	1.2	0.2	1.6	0.4	2.7	0.5	3.9	0.7	5

Selection Worksheet

▼ Complete the following information to select the right products:

Cylinder Selection

Question:	Tips/help	Data	Model Number
Total force required (tonne):	Total load	<input style="width: 100%;" type="text"/>	
Number of cylinders required:	Number of lifting points	<input style="width: 100%;" type="text"/>	
Force per cylinder (tonne):	Should be 80% of total cylinder capacity	<input style="width: 100%;" type="text"/>	
Stroke required:	Plunger travel	<input style="width: 100%;" type="text"/>	
Single or double-acting (D/A):	D/A used when pull force is required, or retract speed is critical!	<input style="width: 100%;" type="text"/>	
Type of plunger required:	Hollow or solid	<input style="width: 100%;" type="text"/>	
Collapsed height required:		<input style="width: 100%;" type="text"/>	
Optional saddle required:	Tilt, Grooved, Flat	<input style="width: 100%;" type="text"/>	
Cylinder base:	Improves stability	<input style="width: 100%;" type="text"/>	
Selected cylinder model:		▶	<input style="width: 100%;" type="text"/>

Pump Selection

The three most commonly selected pumps are hand pumps, electric pumps and air-driven pumps. Gas powered pumps, however can be selected in the same way.

Available power source: Manual Battery Electric Compressed Air Petrol

Hand Pump <u>Single- or double-acting operation</u>		Not for high cycle applications	<input style="width: 100%;" type="text"/>
		Use 4-way valve for D/A applications	<input style="width: 100%;" type="text"/>
		Check speed chart on page 92 for number of stroke per cm	
Selected Hand Pump:		▶	<input style="width: 100%;" type="text"/>
Electric or Compressed Air Pump <u>Need for portability:</u>			
Required useable oil capacity:	1,2 x oil capacity	<input style="width: 100%;" type="text"/>	
	high cycle = 2 x oil capacity		
Available Voltage:		<input style="width: 100%;" type="text"/>	
Lifting speed (Important/not important):	Use speed chart on page 92	<input style="width: 100%;" type="text"/>	
Type of control:	Manual / remote pendant	<input style="width: 100%;" type="text"/>	
Type of actuation/function:	Advance / Hold/ Retract	<input style="width: 100%;" type="text"/>	
Selected Pump:		▶	<input style="width: 100%;" type="text"/>

System Components

Number of hoses and length required:	<input style="width: 100%;" type="text"/>
Selected Hoses:	▶ <input style="width: 100%;" type="text"/>
Manifold or Tee-fitting:	▶ <input style="width: 100%;" type="text"/>
Extra hose per manifold (2):	▶ <input style="width: 100%;" type="text"/>
Gauge (kN or bar scale):	▶ <input style="width: 100%;" type="text"/>
Gauge Adapter:	▶ <input style="width: 100%;" type="text"/>
Fittings:	▶ <input style="width: 100%;" type="text"/>
Pressure Relief Safety Valve:	▶ <input style="width: 100%;" type="text"/>
Load-holding Valve(s):	▶ <input style="width: 100%;" type="text"/>
Hydraulic Oil:	▶ <input style="width: 100%;" type="text"/>



BVA Cross Reference Chart*

Compatibility Check

Tonne	BVA	Enerpac	Power Team	Hi-Force
Single Acting Cylinders				
5	H0500	RC-50	-	HFS51
	H0501	RC-51	C51C	HSS51
	H0503	RC-53	C53C	HSS53
	H0505	RC-55	C55C	HSS55
	H0507	RC-57	C57C	HSS57
	H0509	RC-59	C59C	HSS59
	10	H1001	RC-101	C101C
H1002		RC-102	C102C	HSS102
H1004		RC-104	C104C	HSS104
H1006		RC-106	C106C	HSS106
H1008		RC-108	C108C	HSS108
H1010		RC-1010	C1010C	HSS1010
H1012		RC-1012	C1012C	HSS1012
15	H1501	RC-151	C151C	-
	H1502	RC-152	C152C	HSS152
	H1504	RC-154	C154C	HSS154
	H1506	RC-156	C156C	HSS156
	H1508	RC-158	C158C	-
	H1510	RC-1510	C1510C	HSS1510
	H1512	RC-1512	C1512C	-
25	H2501	RC-251	C251C	-
	H2502	RC-252	C252C	HSS252
	H2504	RC-254	C254C	HSS254
	H2506	RC-256	C256C	HSS256
	H2508	RC-258	C258C	HSS258
	H2510	RC-2510	C2510C	HSS2510
	H2512	RC-2512	C2512C	-
30	H2514	RC-2514	C2514C	HSS2514
	H3008	RC-308	-	HSS308

Tonne	BVA	Enerpac	Power Team	Hi-Force
50	H5502	RC-502	C552C	HSS502
	H5504	RC-504	C554C	HSS504
	H5506	RC-506	C556C	HSS506
	H5513	RC-5013	C5513C	HSS5013
75	H7506	RC-756	C756C	HSS756
	H7513	RC-7513	C7513C	-
100	H10006	RC-1006	C1006C	HSS1006
	H10010	RC-10010	C10010C	HSS10010
Threaded Cylinders				
10	HT1006	-	C106CBT	-
	HT1010	-	C1010CBT	-
Aluminum Cylinders				
20	HU2002T	RAC-202	RA202	-
	HU2004T	RAC-204	RA204	-
	HU2006T	RAC-206	RA206	-
30	HU3002T	RAC-302	RA302	-
	HU3004T	RAC-304	RA304	-
	HU3006T	RAC-306	RA306	HAS306
50	HU5002T	RAC-502	RA552	-
	HU5004T	RAC-504	RA554	-
	HU5006T	RAC-506	RA556	HAS506
700	HU10002T	RAC-1002	RA1002	-
	HU10006T	RAC-1006	RA1006	HAS1006
	HU10010T	RAC-10010	-	-
Low Profile Cylinders				
10	HL1001	RCS-101	RSS101	HLS101
20	HL2002	RCS-201	RSS202	HLS201
30	HL3002	RCS-302	RSS302	HLS302
50	HL5002	RCS-502	RSS502	HLS502
100	HL10002	RCS-1002	RSS1002	HLS1002
Flat Body Cylinders				
5	HF0500	-	RLS50	-
	HF0503	RSM-50	-	HPS50
	HF0503B kit	-	-	-
10	HF1005	RSM-100	RLS100	HPS100
	HF1005B kit	-	-	-

BVA® is a registered trademark of SF Companies.
 Enerpac® is a registered trademark of the Actuant Corporation.
 Power Team® is a registered trademark of SPX Corporation.
 Simplex® is registered of the Actuant Corporation.

BVA Cross Reference Chart*

Compatibility Check

Tonne	BVA	Enerpac	Power Team	Hi-Force
20	HF2005	RSM-200	RLS200	HPS200
	HF2005B kit	-	-	-
30	HF3005	RSM-300	RLS300	HPS300
	HF3005B kit	-	-	-
50	HF5006B	RSM-500	RLS500S	HPS500
75	HF7506	RSM-750	RLS750S	HPS700
100	HF10006	RSM-1000	RLS1000S	HPS1000
150	HF15006	RSM-1500	RLS1500S	HPS1500
Pull Cylinders				
2	HP0205	BRC-25	RP25	-
5	HP0505	BRC-46	RP55	-
10	HP1006	BRC-106	-	-
Hollow Hole Cylinders				
12	HC1201T	RCH-120	RH120	HHS101
	HC1202T	RCH-121	RH121	HHS102
	HC1202XT	RCH-1211	RH121T	-
	HC1203XT	RCH-123	RH123	-
20	HC2002T	RCH-202	RH202	HHS202
	HC2006T	RCH-206	RH206	HHS206
30	HC3002T	RCH-302	RH302	HHS302
	HC3006T	RCH-306	RH306	HHS306
60	HC6003T	RCH-603	RH603	HHS603
	HC6006T	RCH-606	RH606	HHS606
100	HC10003T	RCH-1003	RH1003	HHS1003
Lock Nut Cylinders				
50	HLN5502	CLL-502	R552L	HFG502
	HLN5504	CLL-504	-	-
	HLN5506	CLL-506	R556L	HFG504
	HLN5508	CLL-508	-	-
	HLN5510	CLL-5010	R5510L	HFG506
	HLN5512	CLL-5012	-	-
100	HLN10002	CLL-1002	R1002L	-
	HLN10004	CLL-1004	-	HFG1004
	HLN10006	CLL-1006	R1006L	HFG1006
	HLN10008	CLL-1008	-	-
	HLN10010	CLL-10010	R10010L	-
	HLN10012	CLL-10012	-	-

Tonne	BVA	Enerpac	Power Team	Hi-Force
10	HD1010	RR-1010	RD1010	-
	HD1012	RR-1012	-	-
30	HD3008	RR-308	-	-
	HD3014	RR-3014	RD2514	-
55	HD5506	RR-506	RD556	HDA5506
	HD5513	RR-5013	RD5513	HDA5513
	HD5520	RR-5020	RD5518	-
75	HD7506	RR-756	-	-
	HD7513	RR-7513	-	-
100	HD10006	RR-1006	RD1006	HDA1006
	HD10013	RR-10013	RD10013	HDA10013

BVA	Enerpac	Power Team	Hi-Force
Hand Pumps			
P601S	P-39	P12	HP110
P1201S	P-391	P55	-
P350	P-142	-	HP211
P1000	P-392	P59	HP212
P1201	P-77/P-80	-	-
P2301	P-80	P159	HP227
P4301	P-801	P157	HP257
P8701	P-462	P460	HP245
P2301M	P-84	P157D	-
P8701M	P-464	P460D	HP245D
P240L	P-18	-	-
Air Pumps			
PA600	PA-133	PA9	-
PA600H	-	PA9H	-
PA1500	-	PA6	-
PA1500L	PARG-1102N	PA6R	-
PA1500M	-	PA6DM	-
PA2000	PATG-1102N	-	AHP1120
PA3801	PATG-1105N	PA6-1	AHP1121
PA3801L	-	-	AHP1141
PUR1703	-	PA174	-
PUR4003	ZA4310MX	PA462	-
PURD1701	-	PA172	-
PURD1703	-	PA174	-

*For comparison purposes only. Products are not identical. To view complete cross over list go to www.BVAhydraulics.com

Cross-Referencing / Engineering



Safety Instructions

Industry Safety Standards

General

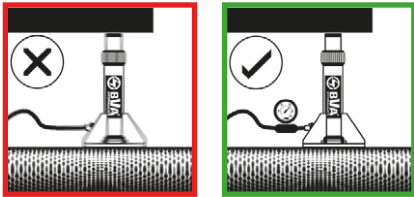

Do not override the factory setting of relief valves. Always use a gauge to check system pressure.

Safety Instructions

- Read and understand all printed materials provided with and on this cylinder
- Do not exceed rated capacities
- Use only on hard level surface capable of sustaining the load
- Do not connect actuators to pumps with higher pressure ratings
- Always inspect hoses and connections for damage prior to use
- Keep hands and feet clear of work area
- LIFTING DEVICE ONLY! Immediately after lifting, support the load with appropriate means
- Use only manufacturer approved hydraulic fluid
- A flow-restricting component shall not be present between the relief valve and the tank
- No alterations shall be made to this cylinder
- Failure to meet these markings may result in injury and/or property damage
- Each double-acting cylinder shall be fitted with a relief valve on the retract circuit, which bleeds off the smaller effective area of the cylinder

Cylinders

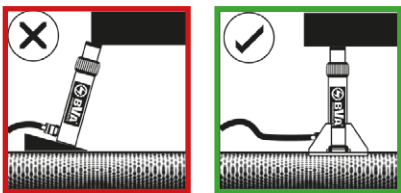

Provide a solid support for the entire cylinder base area. Use cylinder base attachment for more stability.

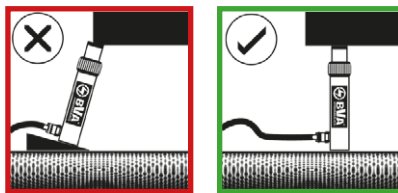

The entire cylinder saddle must be in contact with the load. Movement of the cylinder must be parallel with the movement of the load.

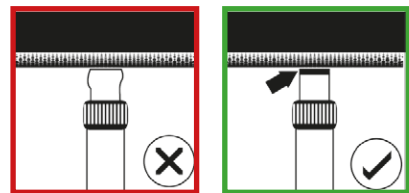

Do not use cylinder without saddle. This will cause plunger to "mushroom" Saddles distribute load evenly on the plunger.

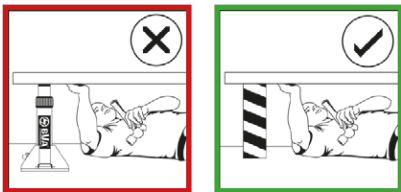

As with jacks, never place any part of your body under the load. Load must be on cribbing before venturing under.

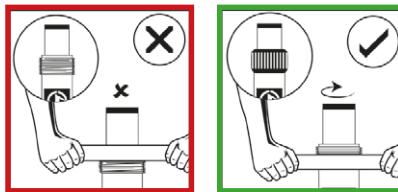

Always protect cylinder threads for use with attachments.

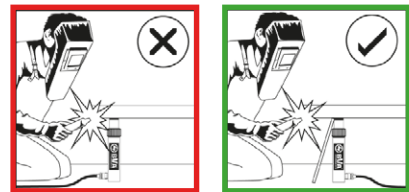

Keep hydraulic equipment away from open fire and temperatures above 150°F (65°C).

Jacks

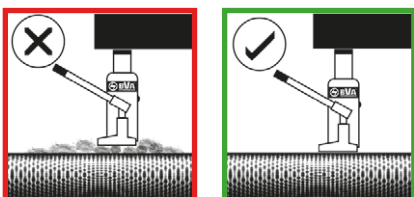

Provide a level and solid support for the entire jack base area.

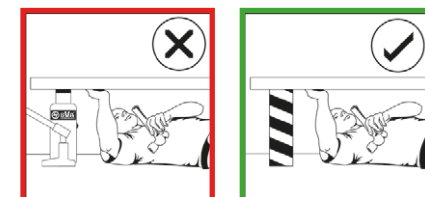

Never place any part of your body under the load. Ensure the load is solidly supported before venturing under.

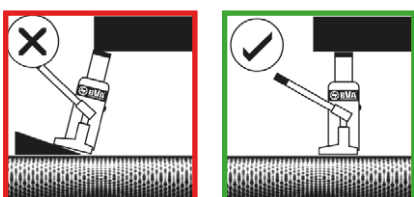

The entire jack saddle must be in contact with load. Movement of the load must be in the same direction as jack plunger.

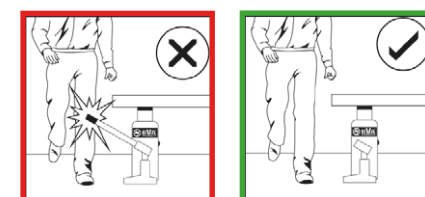

Remove the jack handle when not in use.

80% Rule

Good industry practice recommends not exceeding 80% of maximum rated capacities.

- Use only on hard, level surfaces capable of sustaining the load.
- Immediately after lifting, support the load with appropriate means
- Failure to meet these warnings may result in personal injury as well as property damage.

Hydraulic Pump Safety Instructions

- READ AND UNDERSTAND ALL WARNINGS, INSTRUCTIONS AND OWNER'S MANUAL INFORMATION BEFORE ATTEMPTING TO USE THIS EQUIPMENT
- Burst hazard exists if hose or connection pressure exceeds rated pressure.
- Do not exceed the rated capacity of this device. Monitor pressure and load at all times.
- Verify load with calibrated load cell and indicator, accurate pressure gauge or equivalent devices.
- Inspect hoses and connections for damage prior to use. Never attempt to grasp a leaking pressurized hose.
- Release the hydraulic pressure before disconnecting hoses or couplers, and before servicing the pump or accessory.
- Immediately after lifting, support the load with appropriate means. Never rely on hydraulic pressure to support a load.
- Wear protective clothing and eye protection that meets ANSI Z87.1 and OSHA standards when operating this equipment.
- Ensure that the chosen application is stable to work on and around.
- Do not subject the pump and its components to shock loads.
- Do not connect to applications which can return more oil to the reservoir than the pump reservoir can hold.
- Ensure that the rated pressure of all applications and fittings is equal to or greater than the rated pressure of this pump.
- Keep hydraulic equipment away from flames and heat.
- No alterations shall be made to this device.
- Failure to meet these warnings may result in personal injury as well as property damage.

Pumps



Do not use handle extender. Hand pumps should be easy to operate when used correctly.

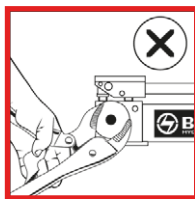

Close release valve finger tight. Using force will damage the valve.

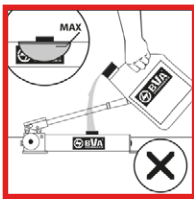
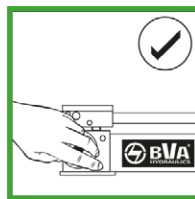

Fill pump only to recommended level. Fill only when connected cylinder is fully retracted.

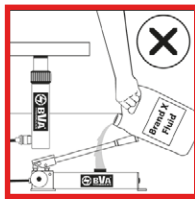
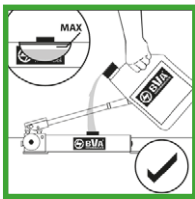

Use only genuine BVA hydraulic oil. The wrong fluid can destroy your seals and pump and will render your warranty null and void.

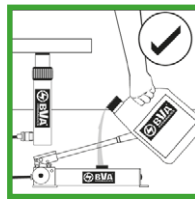

Electric Pump Safety Instructions

TO AVOID ELECTROCUTION HAZARD:

- Owner/Operator must read, understand and follow all printed material provided with this device before use.
- Connect ONLY to properly grounded electrical source. Connect to GFI outlet ONLY! For use in dry locations.
- Avoid the use of extension cords. If used, extension cord lengths up to 7 meter shall be SJT-14X3 or heavier. For cords up to 15 meter, use SJT-12X3 or heavier.
- For extension cord lengths up to 30 meter, use SJT-10X3 or heavier. NEVER use a 3 prong adapter.
- Do not operate this device in an explosive atmosphere or in the presence of conductive liquids.

Hoses and Couplers

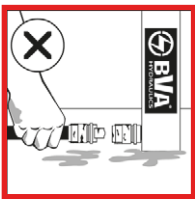

Clean both coupler parts before connecting. Use dust caps when coupler parts are not connected.

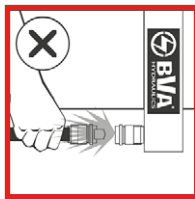
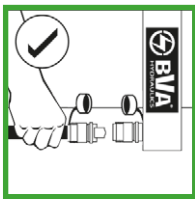

Detach cylinder only when fully retracted or use shut-off valves or safety valves to lock-in cylinder pressure.

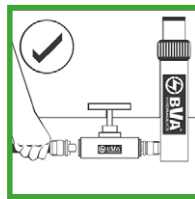

Don't lift hydraulic equipment by the hoses.

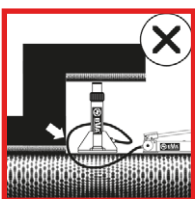
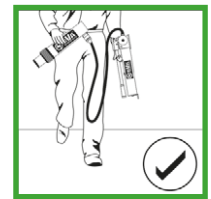

Keep hoses away from the area beneath loads.

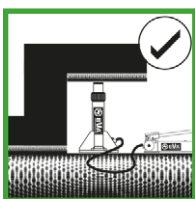

Do not kink hoses. Bending radius should be at least 4 1/2". Do not drive over or drop heavy objects on the hoses.

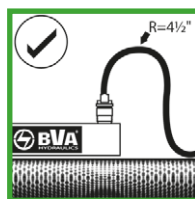



Maintaining Your Equipment

Ensure a longer life span of your equipment

Hydraulic Fluids

- Use only BVA Hydraulic Oil P/N's; HV155 or HV685 for pumps and cylinders.

Air Line Lubricants

- Use Class 1 Turbine Oil (ISO VG32) for Air Line Lubricant

Hydraulic and Pneumatic Filtration

- Hydraulic fluid must be kept clean, cool and free of water.
- Use Hydraulic Filtration to provide fluid which meets ISO 17/15/12 cleanliness levels.
- Air Line Filtration for solid particulate contamination removal: Use BVA P/N; FRL-145, 5uM Pneumatic Filter.
- Air Line Water Removal; Use BVA P/N; AD-145, Ambient Dryer.

Proper Operation of Equipment

- Refer to individual Product Owner's Manuals and BVA Catalogs for general information, specifications, safety, set up, operation, maintenance, trouble shooting, storage and warnings for all BVA products.

Formulas

Key to Measurements			
Weight:		Length	
1 pound (lb.)	=0.4536 kg	1 in	=25.4 mm
1 kg	=2.205 lbs	1 mm	=0.039 in
1 Tonne (short ton, US)	=2,000 lbs	1 in ²	=6.452 cm ²
1 Tonne (metric)	=2,205 lbs	1 cm ²	=0.155 in ²
Volume:		Pressure:	
1 in ³	=16.387 cm ³	1 psi (lb/in ²)	=0.69 bar
1 cm ³	=0.061 in ³	1 bar	=14.5 psi
1 liter	=61.02 in ³	1 kPa	=0.145 psi
	=0.264 gal(US)		
1 gal (US, liquid)	=3.785 liter	Temperature:	
	=231 in ³	0°F	=(0°C x 1.8) + 32
	=3,785 cm ³	0°C	=(0°F - 32) ÷ 1.8

Cylinder Plunger Speed

Formula → $V = \frac{A}{Q} \times 60$
 $Cylinder\ Plunger\ Speed\ (sec/cm^2) = \frac{Cylinder\ Effective\ Area\ (cm^2)}{Pump\ Flow\ Rate\ (cm^3/min)} \times \frac{60\ (sec)}{1\ (min)}$

Force

Formula → $F = P \times A$
 $Force\ (kg) = Hydraulic\ Working\ Pressure\ (kg/cm^2) \times Cylinder\ Effective\ Area\ (cm^2)$

Cylinder Oil Capacity

Formula → $C = A \times L$
 $Oil\ Capacity\ (cm^3) = Cylinder\ Effective\ Area\ (cm^2) \times Cylinder\ Stroke\ (cm)$

1/4" Hose Oil Capacity

Formula → $C = \frac{Internal\ Diameter\ (mm^2)}{4} \times \pi \times Length\ of\ Hose\ (m)$
 $Oil\ Capacity\ (cm^3) = 33 \times Length\ of\ Hose\ (m)$

3/8" Hose Oil Capacity

Formula → $C = \frac{Internal\ Diameter\ (mm^2)}{4} \times \pi \times Length\ of\ Hose\ (m)$
 $Oil\ Capacity\ (cm^3) = 72 \times Length\ of\ Hose\ (m)$

Cylinder Effective Area

Formula → $A = \pi \times \frac{D^2}{4}$
 $Cylinder\ Effective\ Area = \pi \times \frac{(Cylinder\ Bore\ Diameter)^2}{4}$

$\pi = 3.14159265359$

Alphabetical Index

A

AMP	80
AP	82 + 89
APC	84
APE	86 - 87
APH	77 - 83
APHC	79 - 85 + 89
API	81 - 87
APK	83 + 85
APL	82 - 84
APLC	78 - 84
APP	80 - 86
APS	81 - 83 + 87

B

BVA Bag	92
---------	----

C

CA	77
CB	45 + 77
CDC	72
CEB	44
CEBN / CED	43
CEFN / CEN	43
CEP	44
CF	71
CH	73
CM	70
CMH	70
CMRU	74
CP	42
CQ	73
CQF	73
CQH	76
CQR	73
CR	73
CS	73
CSH	67
CVC	69
CVL	69
CVLS	69
CVN	68

CVP	68
CVS	72
CT	90
CVR	68

F

FP	72
FT	77

G

GBW	71
GD	71
GSW	71

H

H	6 - 9
HC	30 - 31
HD	10 - 13
HDC	32 - 33
HDG	26 - 39
HDU	36 - 37
HF	16 - 17
HFS	91
HFSS	91
HG	22 - 25
HGPT	88
HL	14 - 15
HLN	18 - 19
HLNF	20 - 21
HP	42
HPB	42
HPD	43 - 44
HT	41
HTD	34 - 35
HU	34 - 35
HUC	39
HUDC	40
HULN	38
HV	72
HVSP	90

J

J	93
---	----

L

LH	44
----	----

M

MFC	70
-----	----

N

NS	92
NSB	92

P

P	44 - 47
PA	47 - 49
PUAR	54
PUARD	50
PD	62 - 63
PE	56 - 59
PFC	74
PG	62 - 63
PPC	74
PR	75
PU	55
PUW	76
PWS	74
PW	72

S

SA	64 - 65
SD	45
SDT	45
SDTG	45
SDTL	45
SEC	79
SED	79
SMS	78
SP	64 - 65
SR	91

T

TB	66 - 67
----	---------



BVA in action



Shinn Fu Corporation was originally founded as Shinn Fu Auto Supply Company Ltd. by Mr. Michael Hung in 1971 based in Taipei, Taiwan. Shinn Fu has grown into the global leader of hydraulic lifting equipment in the automotive aftermarket. The insistence of producing and offering only the highest quality products has earned Shinn Fu a reputation for exceptional quality in the market.

Started in 1972, Shinn Fu Corporation started manufacturing hydraulic products for the professional and consumer markets. In 2004 the company began manufacturing for the industrial market with BVA Hydraulics. In 2009, due to substantial growth in the industrial market, the company expanded its facilities in Kansas City, MO to better service the North American market.

Shinn Fu Europe B.V. (SFE) was established in 1994 in The Netherlands. With the objective of promoting and distributing Shinn Fu's products in the markets of Europe, Middle East and Northern Africa, SFE launched the Omega Lifting Equipment program in 1994. Since then, Omega has won the market's recognition.

Shinn-Chia Machinery & Foundry (Kunshan) Co., Ltd., a state-of-the-art Foundry, was established in June 1996, began with the casting production in July 1997, and added with the CNC machining processing operations in December 2000. Shinn-Chia is privately owned by the Shinn Fu Group (Taiwan) at www.shinnfu.com.

In order to provide the customers with excellent after-sales service, Shinn Fu has established worldwide branch offices in the USA, Canada, Australia, Hong Kong, Japan and Europe. SFE maintains the following brands: BVA Hydraulics™, Omega Lift Equipment®, Omega Mechanix and Pro-Lift® (<http://www.sftglobal.com/>).

www.BVAhydraulics.com for latest BVA information

Visit the BVA website:

- Learn more about BVA
- New products
- Electronic Catalogs
- Custom Solutions
- Trade shows
- Owner's Manual & Repair Parts
- Nearest Distributors & Service Centers

While every care has been taken in the preparation of this catalog and all data contained within is deemed accurate at the time of printing, Shinn Fu does reserve the right to make changes to the specifications of any product, or discontinue any product, contained within this catalog without prior notice.

All illustrations, performance specifications, weights and dimensions reflect the nominal values and slight variations may occur due to manufacturing tolerances. Please consult Shinn Fu if final dimensions are critical. All information in this catalog can be changed due to product improvements without prior notice.

© Copyright 2022, Shinn Fu. All rights reserved. Any copying or other use of material in this catalog (text, illustrations, drawings, photos) without express written consent is prohibited.

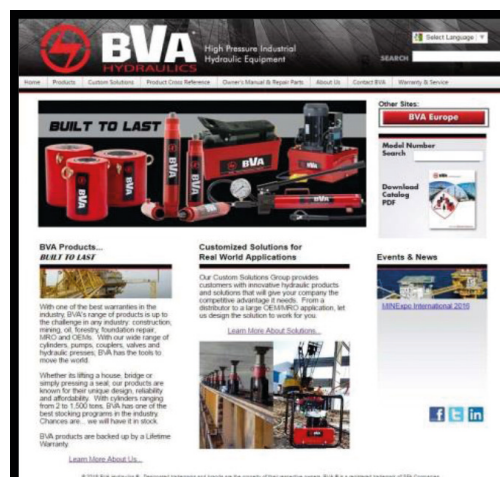



BVA

HYDRAULICS | BUILT TO LAST

Cylinders



Pumps



Combo Kits



Control Valves & Accessories



Presses/Tools



Maintenance Kits/ Bottle Jacks



Cross-Reference & Engineering



Contact Information

Europe

Shinn Fu Europe BV.

Address: Munnikenheiweg 50,
4879 NG Etten-Leur,
The Netherlands

Email: sales.eu@bvahydraulics.com

Tel: +31 (0)165-583300

Fax: +31 (0)165-583310



Online Catalog

Global Locations

Canada

Shinn Fu Canada

Address: 6355 Shawson Dr.
Unit 1 Mississauga,
Ontario L5T 1S7 Canada

Tel: 1-905-362-2277

Fax: 1-905-362-2280

Email: sales@shinnfucanada.ca

United States of America

Shinn Fu America

Address: 10939 N. Pomona Ave.
Kansas City, MO 64153

Tel: 888-332-6419

816-891-6390

Fax: 816-448-2142

Email: sales@bvahydraulics.com

Australia

Shinn Fu Australia

Address: 15 Viewtech Place
Rowville, Victoria
3178, Australia

Tel: 61-3-9755-8277

Fax: 61-3-9755-8219

Email: sales@sfaa.com.au

Taiwan

Shinn Fu Corporation Headquarters

Address: 7F., No.408 Ruei Gaung Rd
Nei Hu District Taipei City
114 Tiawan R.O.C

Tel: 886-2-8751-7888

Fax: 886-2-8741-7999

Email: sales@shinnfu.com